

Installation, Operation, Maintenance and Parts Manual for Backflow Prevention Assemblies

Double Check Valve Assembly Series 2000DCA 4" – 10"

Double Check Detector Assembly Series 3000DCDC 4" – 10"

Reduced Pressure Zone Assembly Series 4000RP 4" – 10"

Reduced Pressure Detector Assembly Series 5000RPDA 4" – 10"

TABLE OF CONTENTS

Caution	2
Application	2
a. Double Check Valve Assembly Series 2000DCA	2
b. Double Check Detector Assembly Series 3000DCDC	2
c. Reduced Pressure Zone Assembly Series 4000RP	2
d. Reduced Pressure Detector Assembly Series 5000RPDA	2
Installation	2
Testing	4
a. Double Check Valve Assembly Series 2000DCA	4
b. Double Check Detector Assembly Series 3000DCDC	4
c. Reduced Pressure Zone Assembly Series 4000RP	5
d. Reduced Pressure Detector Assembly Series 5000RPDA	5
Troubleshooting Guide	6
Problem Identification Procedures	7
Maintenance	8
Parts	12
Warranty	16

Limited Warranty: Ames Company warrants each product to be free from defects in material and workmanship under normal usage for a period of one year from the date of original shipment. In the event of such defects within the warranty period, the Company will, at its option, replace or recondition the product without charge. This shall constitute the sole and exclusive remedy for breach of warranty, and the Company shall not be responsible for any incidental, special or consequential damages, including without limitation, lost profits or the cost of repairing or replacing other property which is damaged if this product does not work properly, other costs resulting from labor charges, delays, vandalism, negligence, fouling caused by foreign material, damage from adverse water conditions, chemical, or any other circumstances over which the Company has no control. This warranty shall be invalidated by any abuse, misuse, misapplication or improper installation of the product. **THIS WARRANTY IS IN LIEU OF ALL OTHER WARRANTIES, EXPRESS OR IMPLIED, INCLUDING ANY IMPLIED WARRANTIES OF MERCHANTABILITY OR FITNESS FOR A PARTICULAR PURPOSE.** Any implied warranties that are imposed by law are limited in duration to one year.

Some States do not allow limitations on how long an implied warranty lasts, and some States do not allow the exclusion or limitation of incidental or consequential damages. Therefore the above limitations may not apply to you. This Limited Warranty gives you specific legal rights, and you may have other rights that vary from State to State. You should consult applicable state laws to determine your rights.

CALIFORNIA PROPOSITION 65 WARNING

WARNING: This product contains chemicals known to the State of California to cause cancer and birth defects or other reproductive harm. (Installer: California law requires that this warning be given to the consumer.)

For more information: www.wattsind.com/prop65



A Division of Watts Industries

875 National Drive • Suite #107 • Sacramento, CA 95834 • Phone: 916-928-0123 • Fax: 916-928-9333

www.amesfirewater.com

INSTALLATION, OPERATION AND MAINTENANCE MANUAL DOUBLE CHECK VALVE ASSEMBLY, DOUBLE CHECK DETECTOR ASSEMBLY, REDUCED PRESSURE ZONE ASSEMBLY, AND REDUCED PRESSURE DETECTOR ASSEMBLY.

CAUTION:

The installation and maintenance of any Ames backflow prevention assembly should be performed by a qualified licensed technician. Failure to do so may result in a malfunctioning assembly. All instructions should be read thoroughly by the technician before installation or performing any maintenance on the assembly.

All Ames assemblies are tested at the factory for proper operation. Any damage or improper opera-

tion caused by debris in pipeline or improper installation is not included in this warranty coverage. If a malfunction occurs or a possible warranty situation exists, follow the instructions in the maintenance manual to correct the problem. CONTACT YOUR LOCAL AMES REPRESENTATIVE.

APPLICATION:

Before any Ames backflow assembly is installed, care should be taken to be sure the correct assembly is being used in the proper application. **Consult your local authority to determine proper device and position for the application.**

A. SERIES 2000DCA

Series 2000DCA (Double Check Valve Assembly) is used to prevent backflow of aesthetically objectionable but not toxic contaminants into the main water supply. The assembly consists of two independently operating internally spring loaded check valves, two shutoff valves and four test cocks.

B. SERIES 3000DCDC

Series 3000DCDC (Double Check Detector Assembly) is used on fire lines to prevent backflow of aesthetically objectionable but not toxic contaminants into the main water supply. It also detects minimal water movement in the fire line system from water theft or water leakage.

The bypass assembly consists of a water meter in series with a double check valve assembly.

C. SERIES 4000RP

Series 4000RP (Reduced Pressure Zone Assembly) is for use on potable water lines where a health hazard could exist in the event of a backflow situation. The assembly consists of two independently operating swing check valves with an independent hydraulically operated differential pressure relief valve, two shutoff valves, and four test cocks.

D. SERIES 5000RPDA

Series 5000RPDA (Reduced Pressure Detector Assembly) is used on firelines where a health hazard could exist in the event of a backflow situation. It also detects any minor water movement in the fireline system from water theft or water leakage. The bypass assembly consists of a water meter in series with a reduced pressure zone assembly.

INSTALLATION INSTRUCTIONS:

A. Before installing any Ames backflow assembly, flush the lines thoroughly to remove all debris, chips and other foreign objects, failure to do so may make the assembly inoperable.

B. Double Check Valve Assemblies and Double Check Detector Assemblies may be placed in any position as long as the flow indicator arrow on the valve is pointed in the direction of water flow, and the local authority has approved installation configuration. RP assemblies are approved by national approval agencies to be installed in a horizontal position. Any other installation configurations must be approved by local authorities.

C. Allow sufficient clearance around the installed assembly to conduct testing, servicing and inspection. Allow a minimum of 12" from the flood level to the bottom of the assembly.

D. If the double check valve or double check detector assembly is installed in a vault or pit be sure proper drainage is available. If sufficient drainage is not available a cross-connection may occur. The RP assembly shall not be installed in a vault or pit.

TYPICAL INSTALLATION

SERIES 2000DCA - 3000DCDC

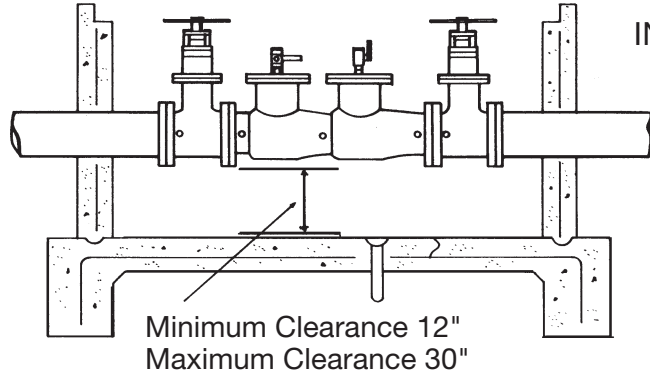

INDOOR INSTALLATION

Minimum Clearance 12"
Maximum Clearance 30"

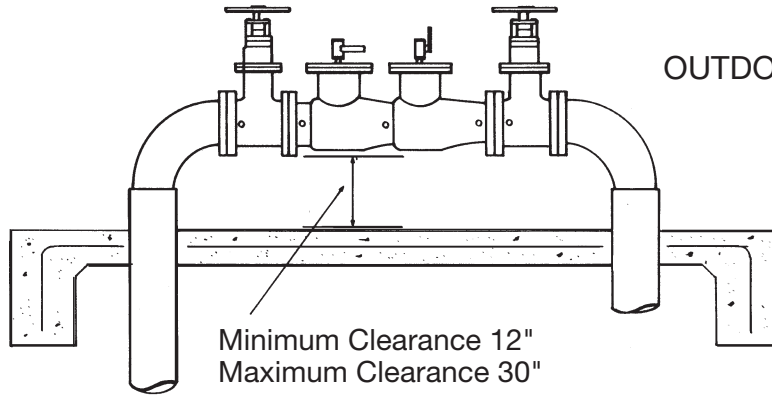

OUTDOOR INSTALLATION

Minimum Clearance 12"
Maximum Clearance 30"

SERIES 4000RP - 5000RPDA

INDOOR INSTALLATION

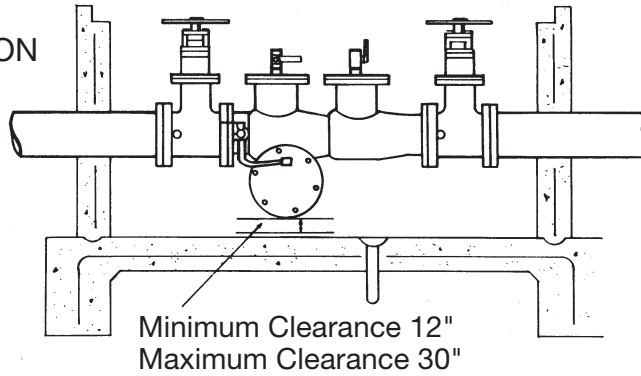

Minimum Clearance 12"
Maximum Clearance 30"

OUTDOOR INSTALLATION

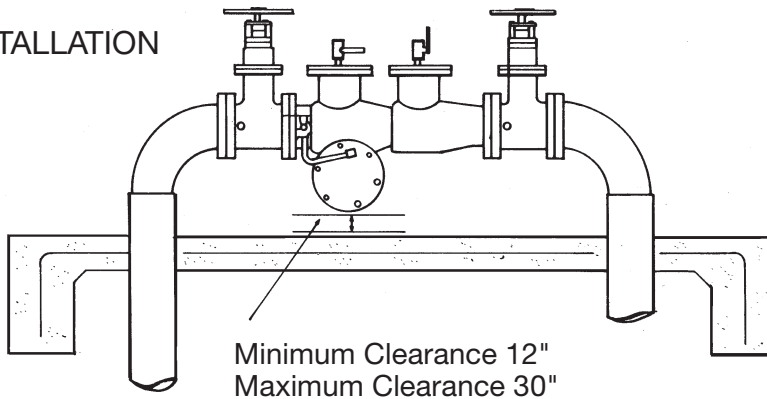

Minimum Clearance 12"
Maximum Clearance 30"

TESTING PROCEDURES: SERIES 2000DCA AND 3000DCDC

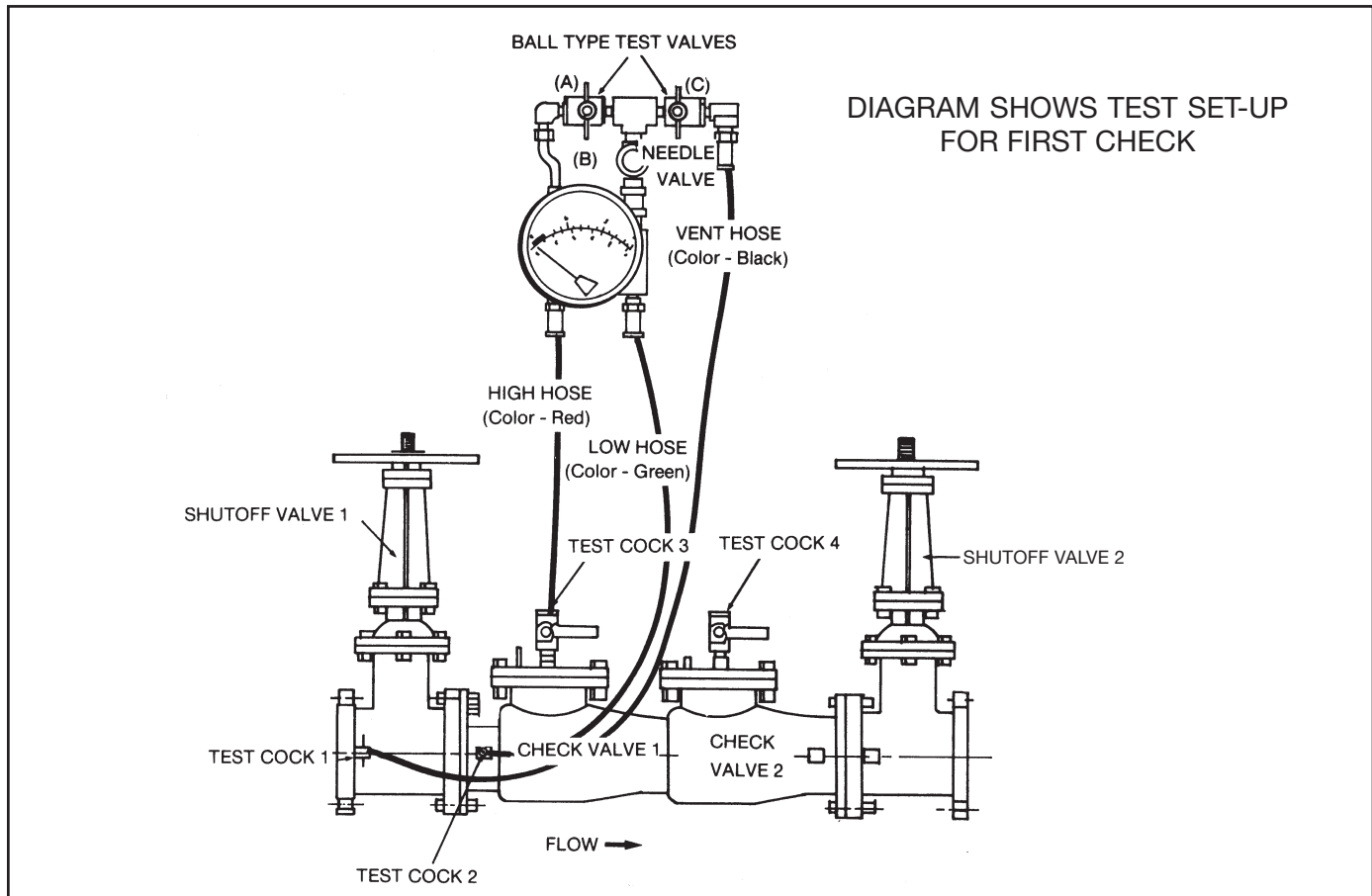

Test Number One

Purpose: To test No. 1 check valve for tightness against reverse flow.

TESTING OF NO. 1 CHECK VALVE

STEP NO. 1 Close No. 1 and No. 2 shutoff valves.

STEP NO. 2 Open test cocks No. 2, 3 and 4. Verify that No. 1 shutoff valve is holding tight by observing that the discharge of water from test cock No. 2 stops.

STEP NO. 3 Attach test kit "Vent" hose to No. 1 test cock; "Low" hose to No. 2 test cock and "High" hose to No. 3 test cock. At this point valves (A) and (C) should be open and (B) should be closed.

STEP NO. 4 Close test cock No. 4.

STEP NO. 5 Open test cock No. 1. The needle of the differential gauge will indicate a pressure in excess of 15 PSID.

STEP NO. 6 Slowly open needle valve (B) until the differential gauge reads 10 PSID. Then close (B). The gauge reading will not change if No. 1 check is holding tight. If No. 1 check is leaking, the gauge will drop to 0.

Requirements: The check valve shall be tight against reverse flow under all pressure differentials.

TESTING OF NO. 2 CHECK VALVE

STEP NO. 1 Close test cock No. 1.

STEP NO. 2 Open test cock No. 4.

STEP NO. 3 Change "Low" hose from test cock No. 2 to test cock No. 3. Change "High" hose from test cock No. 3 to test cock No. 4. On the test kit, valves (A) and (C) should be open and valve (B) should be closed.

STEP NO. 4 Open test cock No. 1. The pressure differential gauge will indicate a pressure in excess of 15 PSID.

STEP NO. 5 Slowly open needle valve (B) until the gauge reads 10 PSID, then close. If the gauge reading does not change, No. 2 check valve is holding tight. If No. 2 check is leaking, the gauge will drop to 0.

NOTE in the above testing: minor leakage in shutoff valve No. 2 will not affect the test results. However, in testing the No. 1 check, leaking shutoff valve No. 1 would cause a good first check to fail the test.

TESTING PROCEDURES: SERIES 4000RP AND 5000RPDA

TEST SET UP

Close Valves (A), (B) and (C) on Test Kit.

Connect the No. 2 Test Cock of the device to the "HIGH" Hose.

Connect the No. 3 Test Cock of the device to the "LOW" Hose.

Close No. 2 shutoff valve of the device.

Open Test Cocks No. 2 and No. 3.

Open "Vent" (C) valve.

Open "High" (A) valve and bleed to atmosphere until all the air is expelled.

Close the "High" (A) valve. Open the "Low" (B) valve and bleed to atmosphere until all air is expelled. Close "Low" (B) valve. Close "Vent" (C) valve.

Connect the No. 4 Test Cock of the device to the "VENT" Hose.

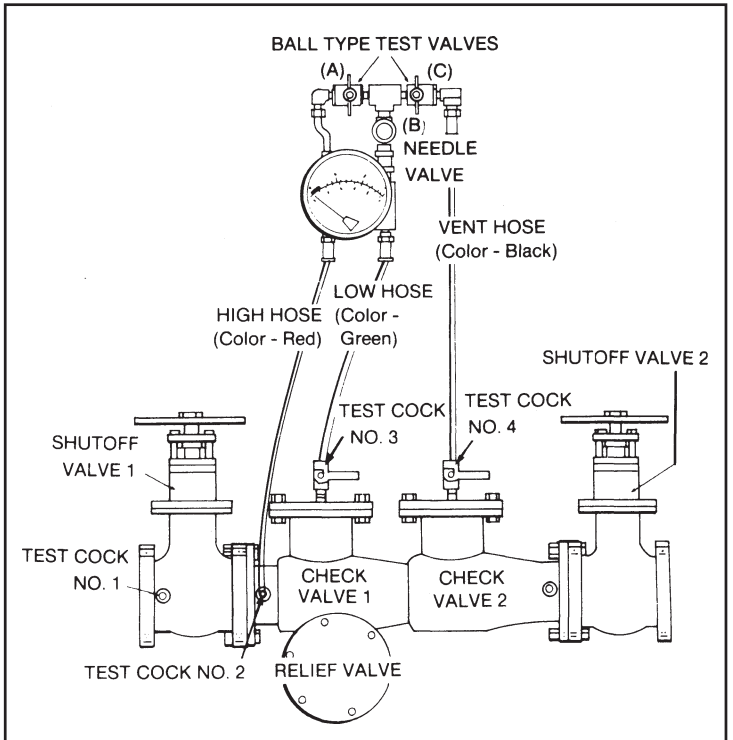

TEST NO. 1

PURPOSE:

To test Check Valve No. 2 for tightness against reverse flow.

REQUIREMENTS:

Valve must be tight against reverse flow under all pressure differentials. Slowly open the "High" (A) and "Vent" (C) valves and keep the "Low" (B) valve closed. Open the No. 4 test cock. Indicated pressure differential will decrease slightly. If pressure differential continues to decrease (until the vent opens) the No. 2 Check Valve is reported as "leaking".

TEST NO. 2

PURPOSE:

To test Shutoff Valve No. 2 for tightness.

REQUIREMENTS:

After passing test No. 1 continue to test No. 2 by closing test cock No. 2. The indicated pressure differential will decrease slightly. If pressure differential continues to decrease (approaching "zero") the No. 2 Shutoff Valve is reported to be "leaking".

TEST NO. 3

PURPOSE:

To test Check Valve No. 1 for tightness.

REQUIREMENTS:

Valve must be tight against reverse flow under all

pressure differentials. Close "High" (A) valve and open Test Cock No. 2. Close Test Cock No. 4. Disconnect "Vent" Hose at Test Cock No. 4. Open valves (B) and (C) bleeding to atmosphere, then closing valve (B) restores the system to a normal static condition. Observe the pressure differential gauge if there is a decrease in the indicated value, the No. 1 Check Valve is reported as "leaking".

TEST NO. 4

PURPOSE:

To test operation of pressure differential relief valve.

REQUIREMENTS:

The pressure differential relief valve must operate to maintain the "zone" between the two check valves at least 2 psi less than the supply pressure. Close "Vent" (C) valve. Open the "High" (A) valve. Open the "Low" (B) valve very slowly until the differential gauge needle starts to drop. Hold the valve at this position and observe the gauge reading at the moment the first discharge is noted from the relief valve. Record this as the opening differential pressure of the relief valve.

NOTE: It is important that the differential gauge needle drops slowly.

Close Test Cocks No. 2 and 3. Use "Vent" Hose to relieve pressure from test kit by opening valves (A), (B) and (C). Remove all test equipment and open No. 2 Shutoff Valve of the device.

TROUBLESHOOTING GUIDE

SERIES 2000DCA AND 3000DCDC

PROBLEM	CAUSE	SOLUTION
Check valve fails to hold minimum	Debris on seating area	eliminate debris
	leaking gate valve (this is determined separately during the test procedure)	repair or replace
	damaged seat	disassemble and replace
	damaged clapper plate	disassemble and replace
	broken spring	disassemble and replace

CHECK VALVE DISC COMPRESSION (When Using A Duplex Pressure Gauge)

During the 'initial test', both the high and low side gauges may drop at the same rate, in which case the check valve would normally be assessed as leaking. However, after both gauges have fallen approximately 10 – 15psi or more, the high side gauge finally drops and holds the required 2psi below the low side gauge. Even though both gauges originally fell together, the check valve is holding tight. The reason for this is that the check valve disc is compressing as a backpressure is created. As the high (upstream) pressure is bled off to drop the 2psi, the downstream pressure begins to push harder on the backside of the check valve. So as the seat imbeds further into the elastomer disc, the volume on the backside of the check valve increases. With an increase in volume there is a corresponding decrease in pressure. So as the high side gauge is lowered, the disc compression causes a lowering on the low side gauge too. Once the disc stops compressing, then the high side gauge will drop below the low side gauge and the check valve will show as holding tight.

SERIES 4000RP AND 5000RPDA

PROBLEM	CAUSE	SOLUTION
A. Assembly discharged from differential relief valve during a no-flow condition	Fouled first check	Disassemble and clean No. 1 check valve
	Fluctuating inlet pressure	Control supply line water pressure
	Outlet pressure higher than inlet pressure & leak in No. 2 check valve	Disassemble clean #2 check valve & identify cause of back pressure
	Leak thru diaphragm or around flange Bolt holes of relief valve	Service relief valve (page 8)
B. Assembly discharges from differential relief valve during a flow condition	Pressure relief valve-does not close	See problem D (pg. 6)
	No. 1 check valve wedged open	Disassemble and clean No. 1 check valve
	O-ring displaced from groove in relief valve	Disassemble and replace
	Pressure relief valve - does not close	See problem D (pg. 6)

PROBLEM	CAUSE	SOLUTION
C. Differential pressure relief valve does not open during test	Differential pressure across No. 1 check valve stays above 2psi due to leaking outlet gate valve	Repair shutoff valves
	Weak or broken relief valve spring	Disassemble and replace relief valve spring
	Seat tube bound in body O-ring	Disassemble and repair
	Plugged hydraulic hose	Disassemble and clean
D. Pressure relief valve - does not close	Debris on sealing surface	Remove relief valve and clean
	Plugged hydraulic hose	Disassemble and clean
	Damaged mounting seat gasket or seat tube	Remove relief valve assembly and replace
	Ruptured diaphragm	Disassemble and replace diaphragm
	Damaged O-ring	Disassemble and replace

PROBLEM IDENTIFICATION PROCEDURES - FOR RPZ ASSEMBLIES

SERIES 4000RP AND 5000RPDA

PROBLEM: Continuous or intermittent discharge from relief valve.

1. When using differential pressure gauge

A. Check differential across No. 1 check valve

Reading	Problem
2 to 3 PSID	Leak in No. 1 or No. 2 check valve
4 to 7 PSID and steady	Malfunctioning pressure relief valve
2 to 7 PSID fluctuating	Inlet pressure fluctuating

2. Without using differential pressure gauge.

A. Close gate valve No. 2

Result	Problem
If discharge stops	Leak in No. 2 check valve
If discharge does not stop	Go to B

B. Open No. 4 test cock to produce a flow greater than differential relief valve discharge

Result	Problem
If discharge stops	Leak in No. 1 check valve
If discharge does not stop	Malfunctioning pressure relief valve

MAINTENANCE INSTRUCTIONS:

Ames backflow prevention assemblies require minimum maintenance. Maintenance on all internal components can be performed without removal of the assembly from line service. All assemblies must be retested once maintenance has been performed.

Removing and Installing Knuckle Joint Assembly (2000DCA and 3000DCDC)

1. Shut down water system and lockout system if possible.
2. Slowly open test cocks or air bleed screw to relieve pressure.
3. Remove all cover plate bolts, lid and cover plate gasket from valve body.
4. Push retainer clip into knuckle joint retention openings located on inner and outer linkages of knuckle joint assembly, until clapper open slightly. (Drawing I).
5. Carefully loosen and remove the two knuckle joint mounting bolts, located on exterior of valve body.
6. Remove knuckle joint assembly from body assuring retainer clip is not disturbed.
7. Bolt the knuckle joint assembly on the exterior of the body through the mounting link holes (Drawing II), or press on hard surface to remove retainer clip.
8. Push on clapper plate to release retainer clip, and remove clip. Slowly remove tension on clapper and unbolt knuckle joint assembly from mounting link holes.

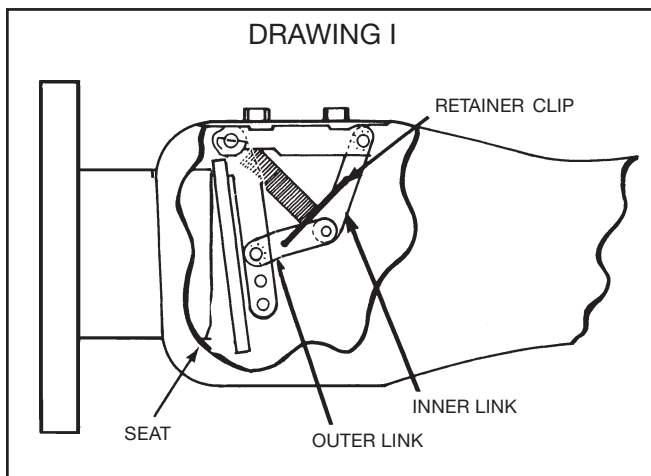

9. Bolt replacement knuckle joint assembly as in step 7 FT LBS.
10. Push on clapper plate to extend spring and install retainer clip. Unbolt knuckle joint assembly from mounting link holes.
11. Insert two New $\frac{3}{8}$ x 1" sealed mounting bolts through mounting holes in body. Position knuckle joint in place inside body, and finger tighten both bolts.

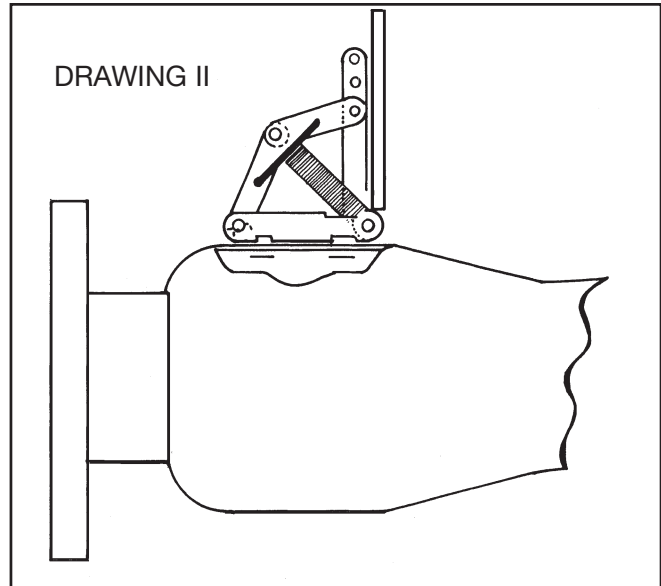

12. Torque knuckle joint mounting bolts to approximately 10 FT LBS.
13. Remove retainer clip
14. Install new gasket with lid. Torque lid bolts to 120 FT LBS.

Removing And Installing Knuckle Joint Assembly (#1 check valve on 4000RP, 1st and 2nd check on 10" 2000 DCA and 3000DCDC).

1. Depressurize assembly.
2. Remove all cover plate bolts, cover and gasket from #1 check.
3. Locate pivot arm of tong tool onto horizontal link pin of knuckle joint (Drawing III).
4. Locate pivot arm of tong tool into adjacent port flange hole.

MAINTENANCE INSTRUCTIONS

5. Remove the two rear mounting **nuts** from exterior of body.
6. While depressing tong tool handle, work rear mounting link away from port tube. (Caution: considerable tension is on tong tool hold firmly).
7. Slowly release controlled pressure on tong tool handle until tension is relieved from springs.
8. Remove tong tool from device.
9. Remove 2 - $\frac{3}{8}$ " mounting **bolts** from front of body.
10. Remove knuckle joint assembly from body.
11. Reinstall new knuckle joint assembly by reversing above procedure.

DRAWING III

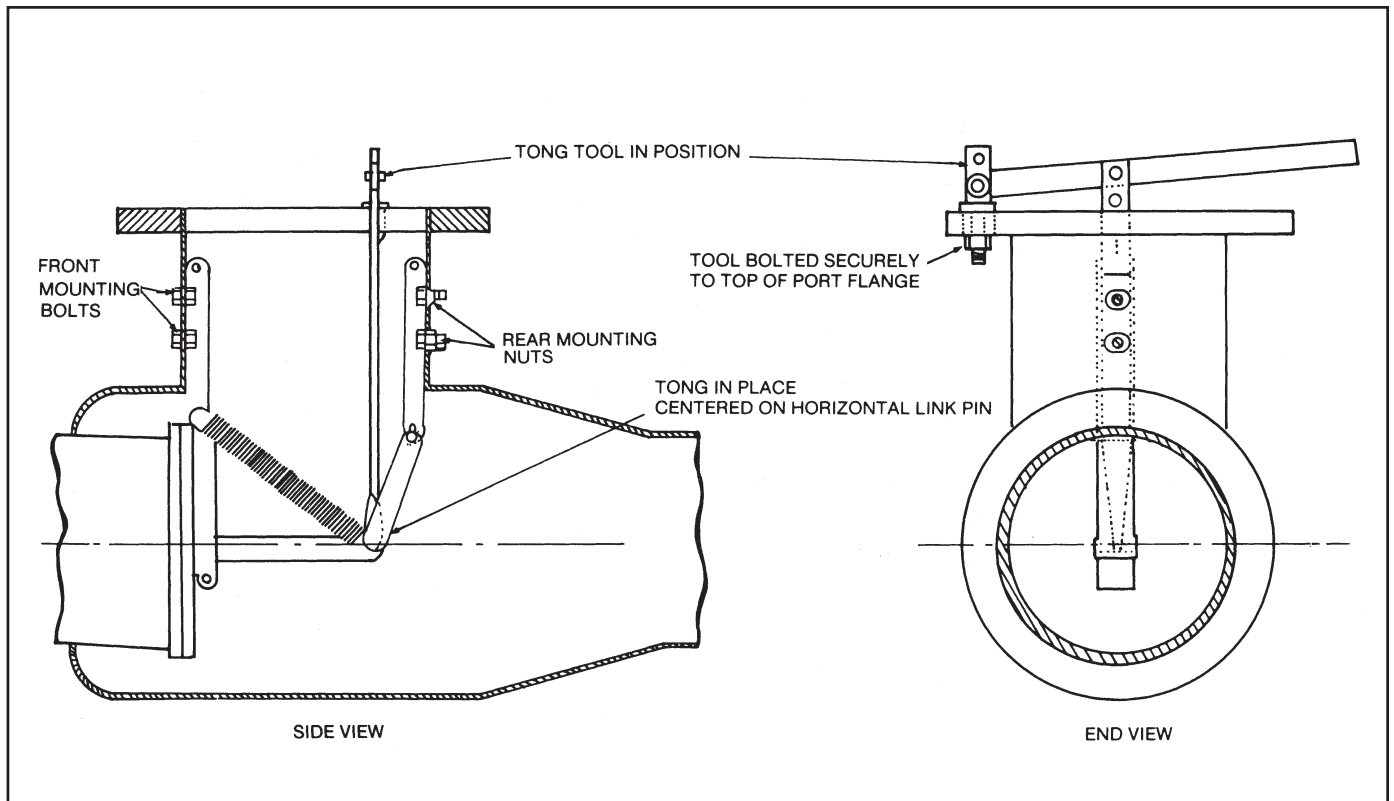

REMOVAL AND REPAIR OF RELIEF VALVE (See Drawing Page 15)

1. Depressurize assembly. Disconnect hose and remove relief valve from elbow flange. Inspect rubber relief valve mounting seat gasket for debris, cutting or distortion of rubber. Remove $\frac{5}{16}$ " lid bolts.
2. Disassemble piston assembly by unscrewing top diaphragm plate from seat tube in counter clockwise direction. Remove O-ring from relief valve body. Clean and inspect all parts for damage, debris or buildup. Clean and inspect vent hole in seat tube and O-ring groove in body.
3. Place small amount of FDA approved lubricant on O-ring groove, seat tube OD, O-ring guide pin and diaphragm plate threads. (Do not use petroleum or solvent based lubricant). Clean O-ring groove on top washer plate. Hold top washer plate with threaded side up. Set diaphragm on washer plate with side marked HIGH PRESSURE SIDE down, install bottom washer plate with spring guide shoulder away from diaphragm. Set seat tube on threaded stub of washer plate and slowly engage threads. Hand tighten seat tube in clockwise direction.

4. Stretch to 3" diameter and lubricate O-ring and place in O-ring groove. Place relief valve spring in body. Place lid with bolts on piston assembly and thread diaphragm over bolts. Ensure that diaphragm is not pinched between lid and washer plate. Reassemble unit assuring spring is seated over guide and that tube is carefully pushed through O-ring in body. Hand tighten bolts. If O-ring has been pushed from groove, disassemble, inspect for damage, and repeat assembly.

Clean and place rubber seat mounting gasket in recess with raised O-ring side out. Before installing relief valve, slightly open #1 gate valve to ensure hose is free of debris and debris is washed from main body. Bolt relief valve to mainline valve and install hose. Open #1 gate valve and bleed air from all test cocks and air vents on relief valve.

5. Test assembly.

MAINTENANCE INSTRUCTIONS:

I. Removing Bronze Seat (all assemblies except #1 RP, 8" and 10" DC and DCDC)

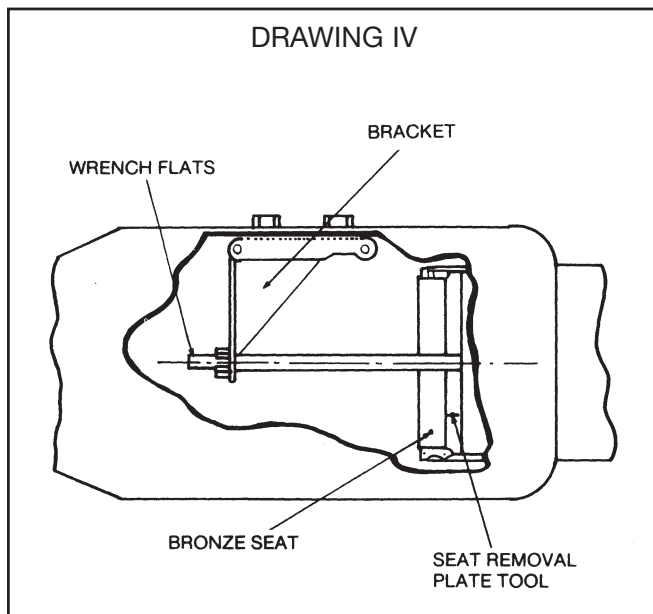

1. Remove knuckle joint assembly. (Instructions pg. 8)
2. Insert seat replacement bracket into interior of body and install where knuckle joint was located.

3. Place seat removal tool beyond seat into pulling position.
4. Install rod through bracket seat and thread into seat removal tool.
5. Thread nut and washer onto rod until contact with bracket.
6. Place wrench on rod flats, while using another wrench to tighten nut until seat dislodges from body.
7. Remove seat and all tooling except bracket from body.

MAINTENANCE INSTRUCTIONS:

Installing New Bronze Seat (Drawing V)

1. Clean debris from seat area.
2. Lubricate seat area with water soluble FDA approved lubricant.
3. Install tooling as per Drawing V.
4. Using two crescent wrenches, tighten nuts on rod in opposite directions until seat, with O-ring, is securely into place. Visually inspect seat to ensure contact with body.
5. Remove tooling.
6. Install knuckle joint and lid.

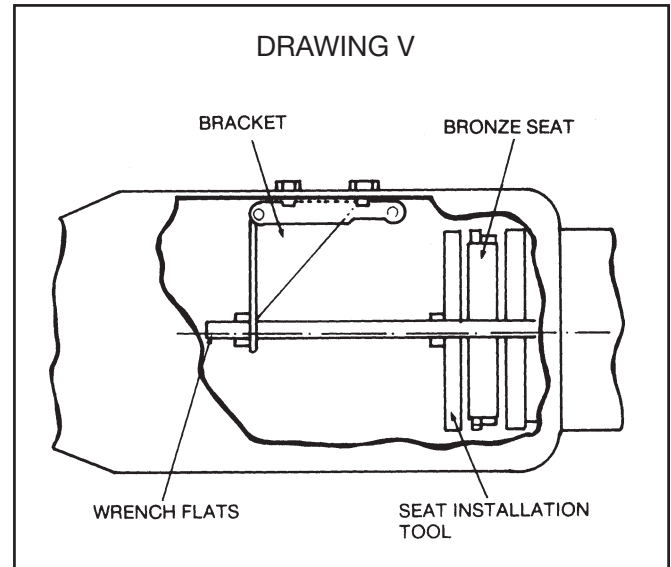

II. Removing and Installing bronze seat (1st check 4000RP and 8" and 10" DC & DCDC)

Drawing VI

Note: Procedure is identical to previous removal and installation of seat.

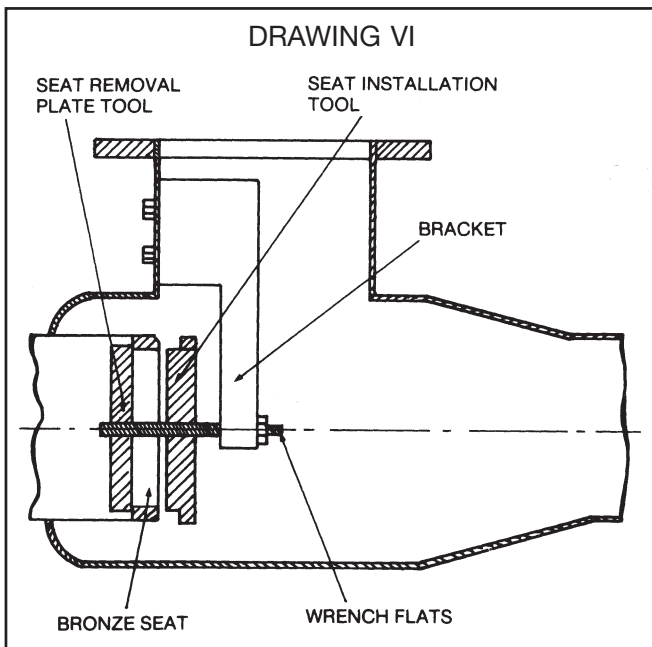

PARTS SERIES 2000DCA AND 3000DCDC

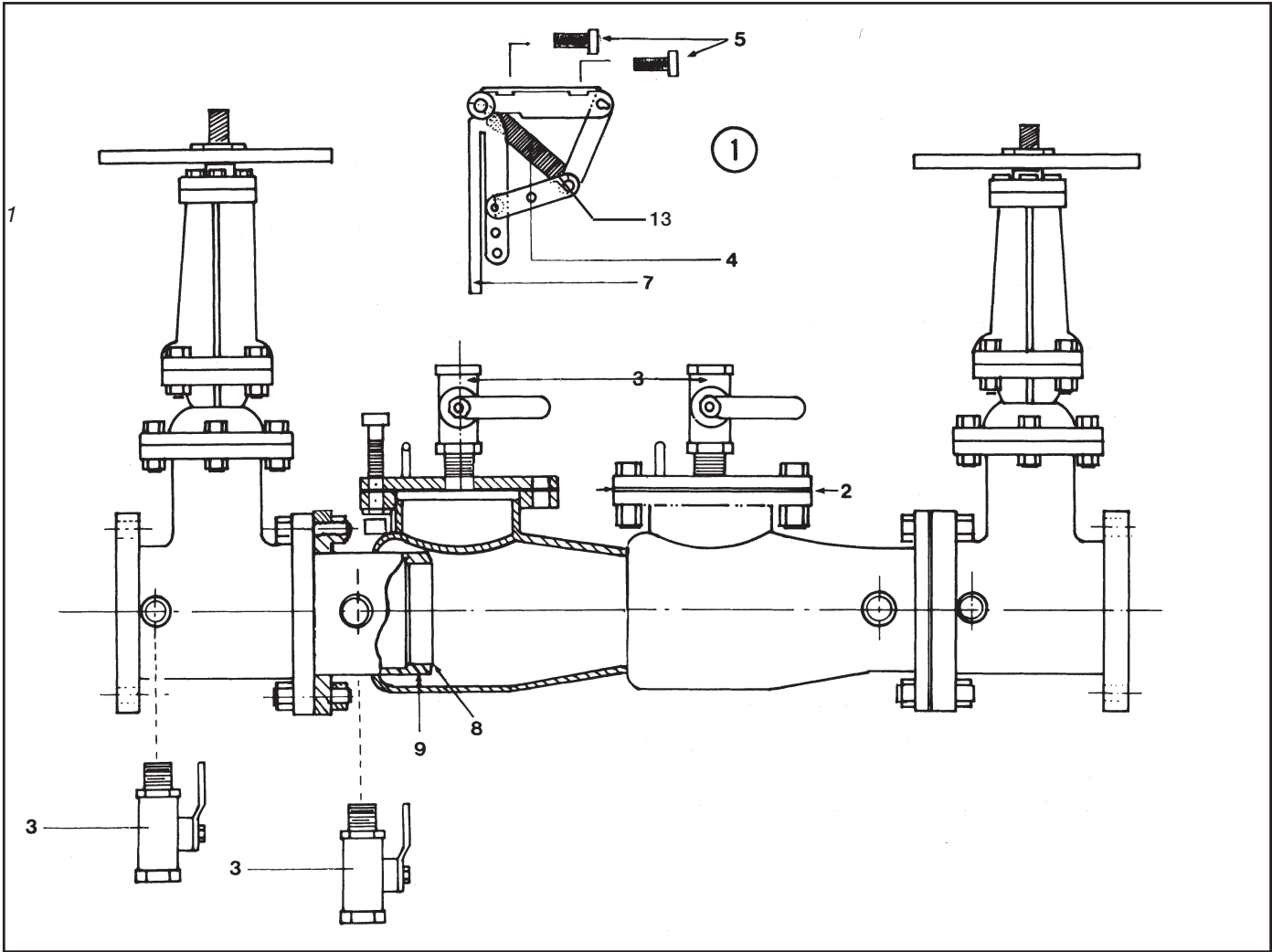

ITEM NO.	DESCRIPTION	QTY.	SIZE 4"	SIZE 6"	SIZE 8"	SIZE 10"
1	DCA Knuckle Joint Assembly	1	7011441	7011220	7011433	7011236
1a	DCDC Knuckle Joint Assembly (not shown)	1	7011442	7011426	7011257	7011236
2	Bonnet Gasket	1	7011199	7011124	7011125	7011125
3	Ball Valve	4	7014668	A000449	A000449	A000449
4	DCA Spring	2	7011322	7011128	7011323	7011319
4a	DCDC Spring (# of springs required)		7011320 2	7011128 (3) #1 ck	7011323 3	7011319 2
5	3/8" Stainless Steel Housing Bolts	2	7014619	7014619	7014619	7014619
6	Washer (rubber faced) (not shown)	2	7014585	7014585	7014585	7014585
7	Clapper Plate (rubber faced)	1	7011418	7011419	7011420	7011420
8	Bronze Seat Ring	1	7011160	7011162	7011163	7011163
9	Seat O-ring	1	7011161	A300704	A300706	A300706
10	Clapper Retainer Clip (not shown)	1	7013911	7013912	7013913	7013913
11	Tong Tool (not shown)	1	7016090	7016090	7016090	7016090
12	Seat Install and Removal Tool (not shown)	1	7013941	7013946	7013950	7013950
13	Linkage Retainer Clip	1	7011037	7011037	7011037	7011037

PARTS SERIES 4000RP EPOXY

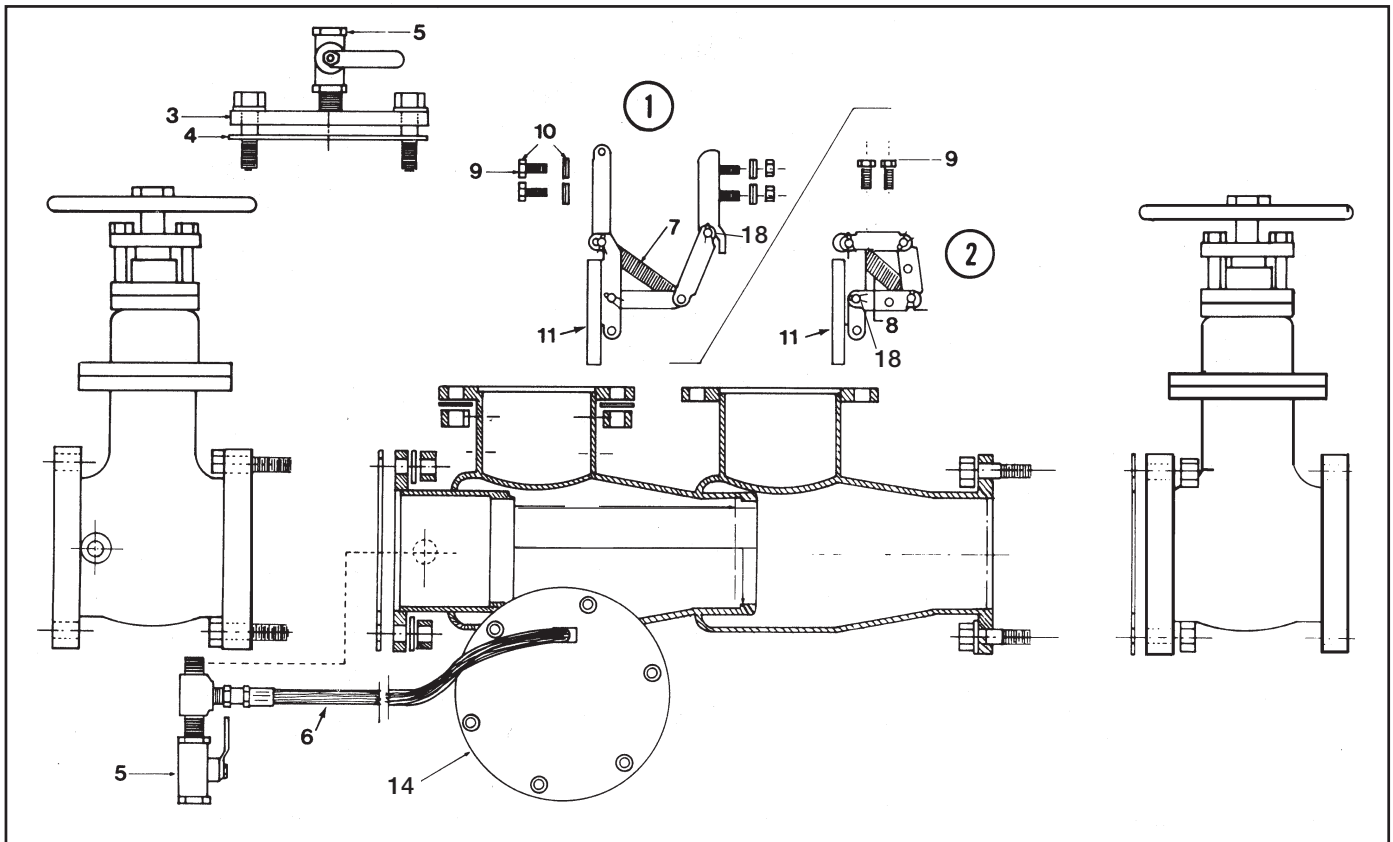

ITEM NO.	DESCRIPTION	QTY.	SIZE 4"	SIZE 6"	SIZE 8"	SIZE 10"
1	1st Knuckle Joint Assembly	1	7011208	7011415	7015553	7015553
2	2nd Knuckle Joint Assembly	1	7011441	7011220	7011257	7011257
3	Bonnet Flange and Cover	1	7011430	7011442	7011453	7011453
4	Bonnet Gasket	1	7011199	7011124	7011125	7011125
5	Ball Valve	4	7014668	A000449	A000449	A000449
6	Braided Hose	1	7014645	7014645	7014645	7014645
7	1st Assembly Springs (# of springs required)		7011320 2	7011319 2	7011319 5	7011319 5
8	2nd Assembly Springs (# of springs required)		7011322 2	7011128 2	7011323 3	7011323 3
9	3/8" Stainless Steel Housing Bolts	2	7014619	7014619	7014619	7014619
10	Washer (rubber faced)	2	7014585	7014585	7014585	7014585
11	Vulcanized Clapper Plate	1	7011418	7011419	7011420	7011420
12	Bronze Seat Ring (not shown)	1	7011160	7011162	7011163	7011163
13	Seat O-ring (not shown)	1	7011161	A300704	A300706	A300706
14	Relief Valve	1	7011283	7011283	7011283	7011283
15	Clapper Retainer Clip (not shown)	1	7013911	7013912	7013913	7013913
16	Tong Tool (all sizes) (not shown)	1	7016090	7016090	7016090	7016090
17	Seat Install and Removal Tool (not shown)	1	7013941	7013946	7013950	7013950
18	Linkage Retainer Clip	1	7011037	7011037	7011037	7011037

NOTE: Same relief valve is used on all valve 4" through 10"

PARTS SERIES DC - DCDC

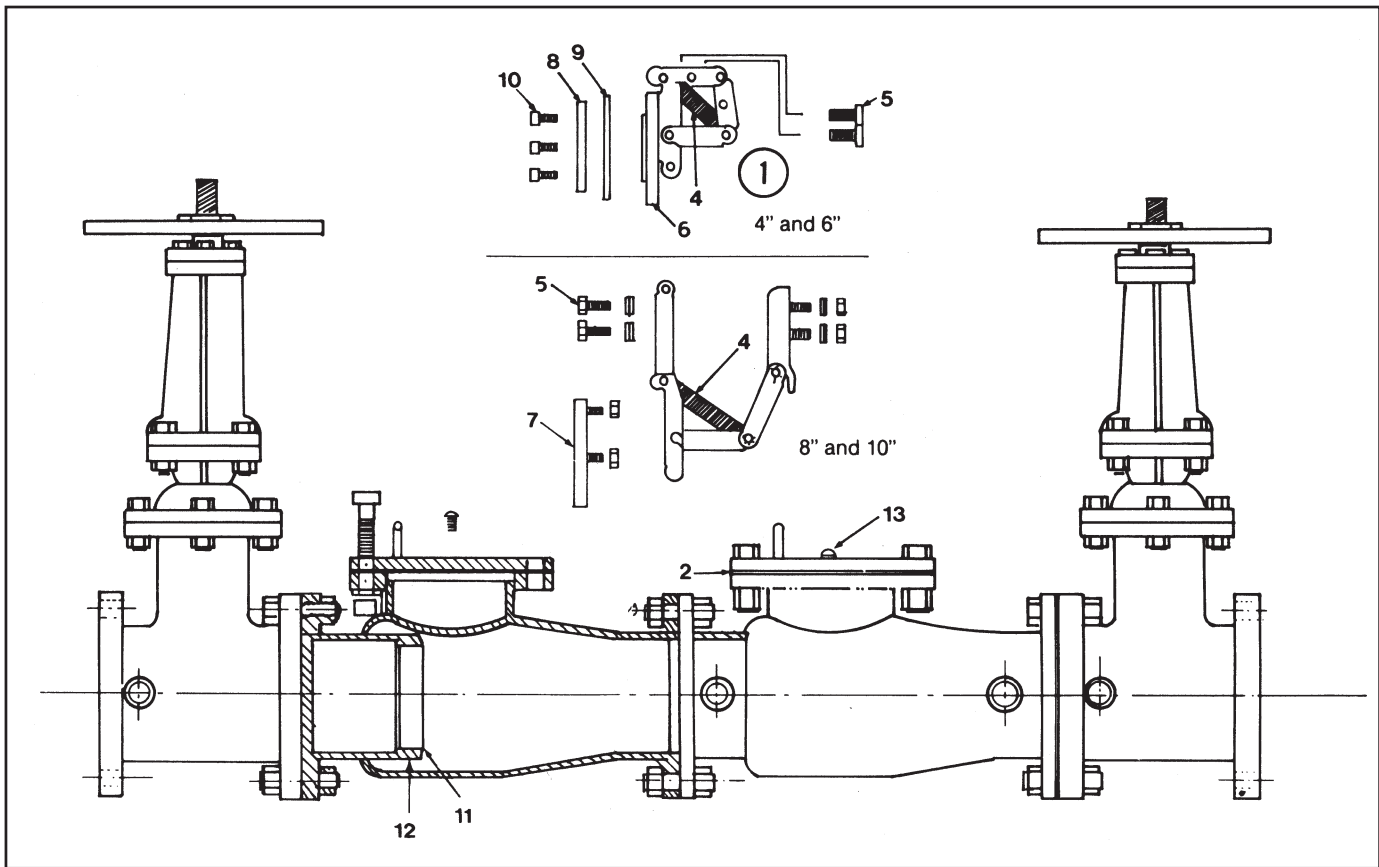

ITEM NO.	DESCRIPTION	QTY.	SIZE 4"	SIZE 6"	SIZE 8"	SIZE 10"
1	Knuckle Joint Assembly (1st & 2nd identical)	1	7011224	7011142	7011236	7011236
2	Bonnet Gasket	1	7011123	7011124	7011125	7011125
3	Ball Valve	4	A000449	A000449	A000449	A000449
4	Spring	2	7011320	7011128	7011319	7011319
5	3/8" Stainless Steel Housing Bolts	2	7014619	7014619	7014619	7014619
6	Washer (rubber faced)	2	7014585	7014585	7014585	7014585
7	Clapper Plate	1	7011228	7011229	7011420	7011420
8	Retainer Plate	1	7011226	7011145	—	—
9	Molded Rubber Clapper Insert	1	7011227	7011144	—	—
10	Clapper Keeper Bolts	3	A000483	A000483	—	—
11	Seat	1	7011160	7011162	7011163	7011163
12	Seat O-ring	1	7011161	A300704	A300706	A300706
13	Vent Screw	1	7011133	7011133	7011133	7011133
14	Tong Tool	1	7016090	7016090	7016090	7016090
15	Clapper Retainer Clip (not shown)	1	7013911	7013912	7013913	7013913
16	Seat Install and Removal Tool (not shown)	1	7013941	7013946	7013950	7013950
17	Linkage Retainer Clip	1	7011037	7011037	7011037	7011037

PARTS SERIES 5000RPDA EPOXY

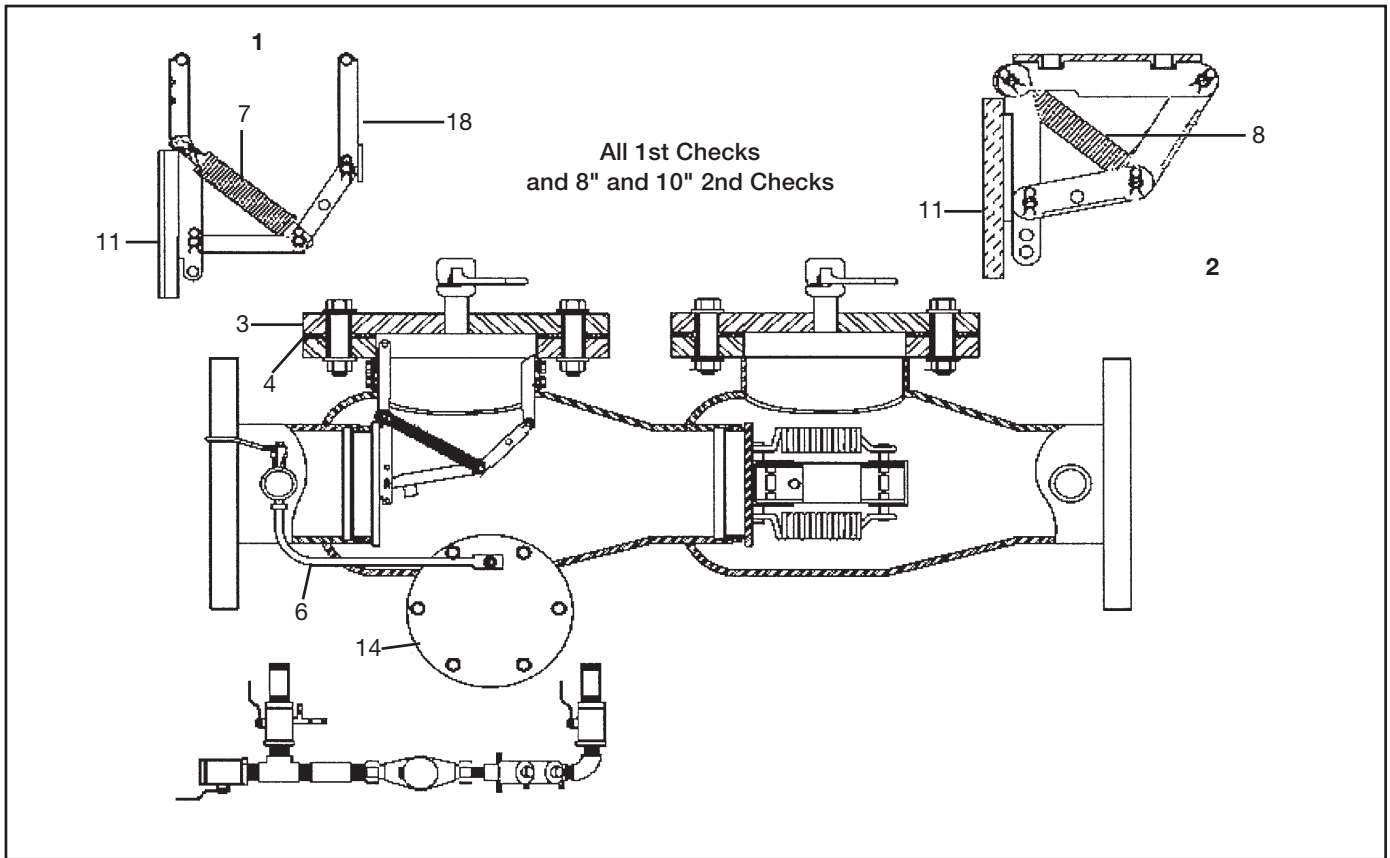

ITEM NO.	DESCRIPTION	QTY.	SIZE 4"	SIZE 6"	SIZE 8"	SIZE 10"
1	1st Knuckle Joint Assembly	1	7011414	7011415	7015553	7015553
2	2nd Knuckle Joint Assembly	1	7011441	7011426	7011236	7011236
3	Bonnet Flange and Cover	1	7011430	7011442	7011453	7011453
4	Bonnet Gasket	1	7011199	7011124	7011125	7011125
5	Ball Valve	4	7014668	A000449	A000449	A000449
6	Braided Hose	1	7014645	7014645	7014645	7014645
7	1st Assembly Springs (# of springs required)		7011320 2	7011319 2	7011319 5	7011319 5
8	2nd Assembly Springs (# of springs required)		7011322 2	7011128 2	7011323 3	7011323 3
9	3/8" Stainless Steel Housing Bolts	2	7014619	7014619	7014619	7014619
10	Washer (rubber faced)	2	7014585	7014585	7014585	7014585
11	Vulcanized Clapper Plate	1	7011418	7011419	7011420	7011420
12	Bronze Seat Ring	1	7011160	7011162	7011163	7011163
13	Seat O-ring (not shown)	1	7011161	A300704	A300706	A300706
14	Relief Valve	1	7011283	7011283	7011283	7011283
15	Clapper Retainer Clip (not shown)	1	7013911	7013912	7013913	7013913
16	Tong Tool (all sizes)	1	7016090	7016090	7016090	7016090
17	Seat Install and Removal Tool	1	7013941	7013946	7013950	7013950
18	Linkage Retainer Clip	1	7011037	7011037	7011037	7011037

PARTS DIFFERENTIAL PRESSURE RELIEF VALVE FOR SERIES 4000RP

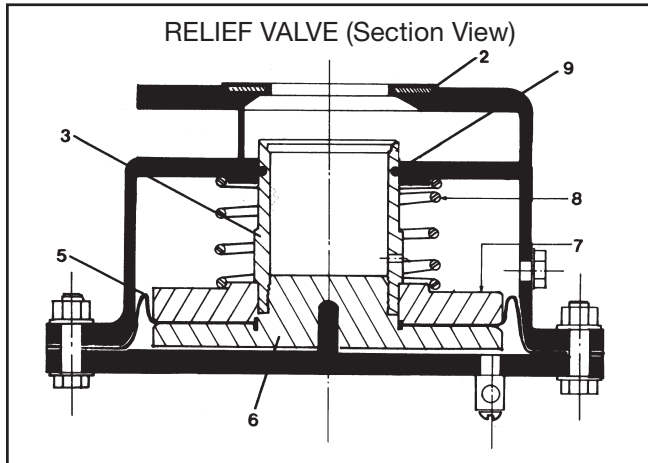

ITEM NO.	DESCRIPTION	QTY.	PART #
1	Complete	1	7011283
2	Mounting Seat Gasket	1	7011295
3	Stainless Steel Seat Tube	1	7011290
4	Mounting Bolt (not shown)	4	7014619
5	Diaphragm	1	7011292
6	Diaphragm Top Plate	1	7011291
7	Diaphragm Bottom Plate	1	7011294
8	Spring	1	A300887
9	O-ring	1	7011233
10	Repair Kit (#2, #5, #9)	1	7013955

NOTE: Same relief valve is used for all size mainline valves 4" through 10"

NOTE: The Ames Differential Pressure Relief Valve (relief valve) is designed to open and discharge if the first mainline check is fouled; accordingly if the relief valve is discharging the first service procedure is to examine the first check for fouling. The Ames relief valve requires minimal service requirements.

AIR GAP DRAIN

APPLICATION

The Air Gap Drain is designed to be installed under the relief valve on Ames RP and RPDA devices to catch minor relief valve discharges created by pressure fluctuations of the supply line. The Ames Air Gap Drain is approved by the USC FCCCHR.

INSTALLATION INSTRUCTIONS

- Before installation, check with local authorities as an air gap drain is not approved for all installations.
- Remove lower two relief valve mounting bolts.
- Align bolt holes on air gap drain with holes in relief valve flange.
- Insert the two bolts which were removed in Step B through air gap drain and relief valve flange, then tighten.

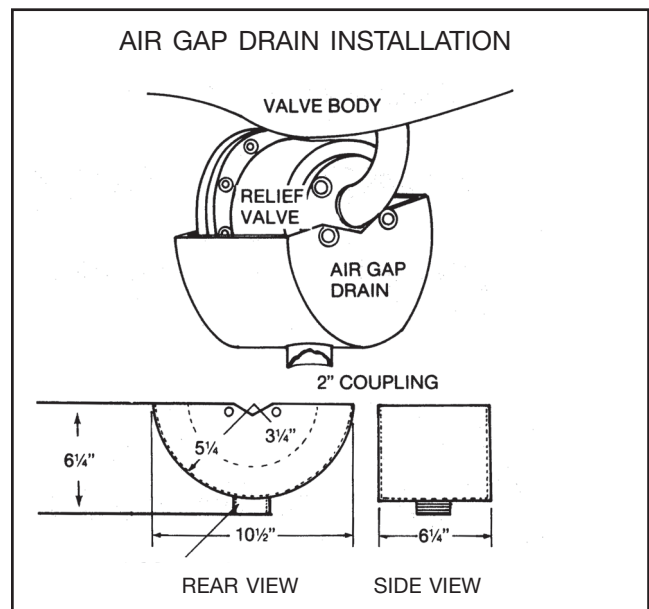

Price List, Product Series or Design are subject to change without notice.



A Division of Watts Industries

www.amesfirewater.com



875 National Drive • Suite #107 • Sacramento, CA 95834 • Phone: 916-928-0123 • Fax: 916-928-9333