

Double Check Valve Assemblies & Double Check Detector Assemblies

Sizes: 2 1/2" – 6"SS (65 – 150mm)
6" – 8"SE (150 – 200mm)

- Installation
- Service
- Repair Kits
- Maintenance



Installation Note: The flange gasket bolts for the gate valves should be retightened during installation as the bolts may have loosened due to storage and shipping.

For other repair kits and service parts, send for Ames Repair Parts Price List, PL-A-RP-BPD.

For technical assistance, contact your local Ames representative.

IMPORTANT: Inquire with governing authorities for local installation requirements.

NOTE: For Australia and New Zealand, line strainers should be installed between the upstream shutoff valve and the inlet of the backflow preventer.

Its important that this assembly be tested periodically in compliance with local codes, but at least once per year or more as service conditions warrant. If installed on a fire sprinkler system, all mechanical checks, such as alarm checks and backflow preventers, should be flow tested and inspected internally in accordance with NFPA 13 and NFPA 25.

Limited Warranty: Ames Company warrants each product to be free from defects in material and workmanship under normal usage for a period of one year from the date of original shipment. In the event of such defects within the warranty period, the Company will, at its option, replace or recondition the product without charge. This shall constitute the sole and exclusive remedy for breach of warranty, and the Company shall not be responsible for any incidental, special or consequential damages, including without limitation, lost profits or the cost of repairing or

replacing other property which is damaged if this product does not work properly, other costs resulting from labor charges, delays, vandalism, negligence, fouling caused by foreign material, damage from adverse water conditions, chemical, or any other circumstances over which the Company has no control. This warranty shall be invalidated by any abuse, misuse, misapplication or improper installation of the product. **THIS WARRANTY IS IN LIEU OF ALL OTHER WARRANTIES, EXPRESS OR IMPLIED, INCLUDING ANY IMPLIED WARRANTIES OF MERCHANTABILITY OR FITNESS FOR A PARTICULAR PURPOSE.** Any implied warranties that are imposed by law are limited in duration to one year.

Some States do not allow limitations on how long an implied warranty lasts, and some States do not allow the exclusion or limitation of incidental or consequential damages. Therefore the above limitations may not apply to you. This Limited Warranty gives you specific legal rights, and you may have other rights that vary from State to State. You should consult applicable state laws to determine your rights.

CALIFORNIA PROPOSITION 65 WARNING

WARNING: This product contains chemicals known to the State of California to cause cancer and birth defects or other reproductive harm. (Installer: California law requires that this warning be given to the consumer.)

For more information: www.wattsind.com/prop65

A Division of Watts Industries

875 National Drive • Suite #107 • Sacramento, CA 95834 • Phone: 916-928-0123 • Fax: 916-928-9333

www.amesfirewater.com



Installation Instructions

Please Read Prior to Installation:

1. Before installing any Ames backflow assembly, flush the line thoroughly to remove all debris, chips and other foreign objects. Failure to do so may make the assembly inoperable.
2. The Ames 2000SS and 3000SS may be placed in any position as long as the flow indicator arrow in the assembly is pointed in the direction of water flow, and the local water authority has approved the installation configuration. ASSE (American Society of Sanitary Engineers) has approved these assemblies for either horizontal or vertical installation.

3. Allow sufficient clearance around the installed assembly to conduct testing, servicing, and inspection. Allow a minimum of 12" from the flood level to the bottom of the assembly.
4. If double check or double check detector assembly is installed in a vault or pit, be sure proper drainage is available. If sufficient drainage is not available a cross-connection may occur.

Attention Installer: After installation, please leave this Instruction Sheet for occupant's information.

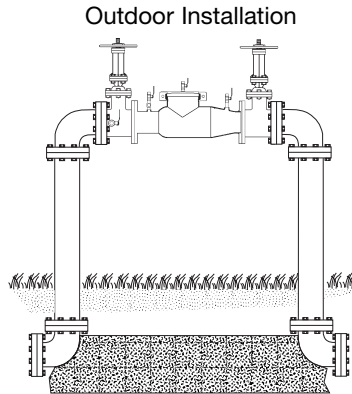
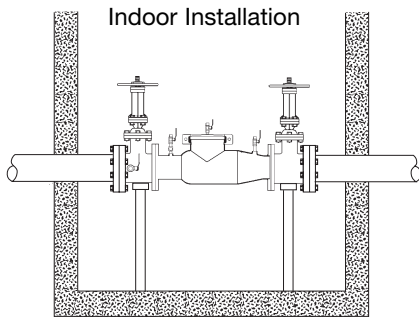

Vertical Installation

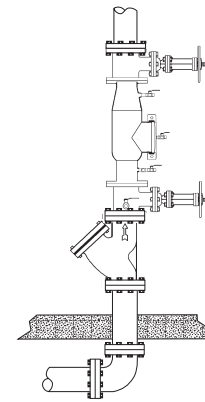

Detailed Parts Listing

Parts Table #1

Item #	Description	Qty	Ames Part No.					
			2 1/2"	3"	4"	6"SS	6"SE	8"SE
1.	#1 Cam-Check	1	7015559	7015559	7015559	7015564	7015559	7015564
2.	#2 Cam-Check	1	7015560	7015560	7015560	7015565	7015560	7015565
3.	#1 Cam-Check O-ring	1	7015333	7015333	7015333	7013280	7015333	7013280
4.	#2 Cam-Check O-ring	1	7013229	7013229	7013229	7013281	7013229	7013281
5.	Cover Plate	1	7013241	7013241	7013241	7013289	7013474	7013289
6.	Ball Valve	2	A000449	A000449	A000449	A000449	A000449	A000449
7.	Groove Coupler	1	7013194	7013194	7013194	7013287	7013194	7013287
8.	Groove Coupler Gasket	1	7013248	7013248	7013248	7013308	7013248	7013308
9.	Ball Valve (Cover)	1	A603134	A603134	A603134	7013034	7013034	7013034

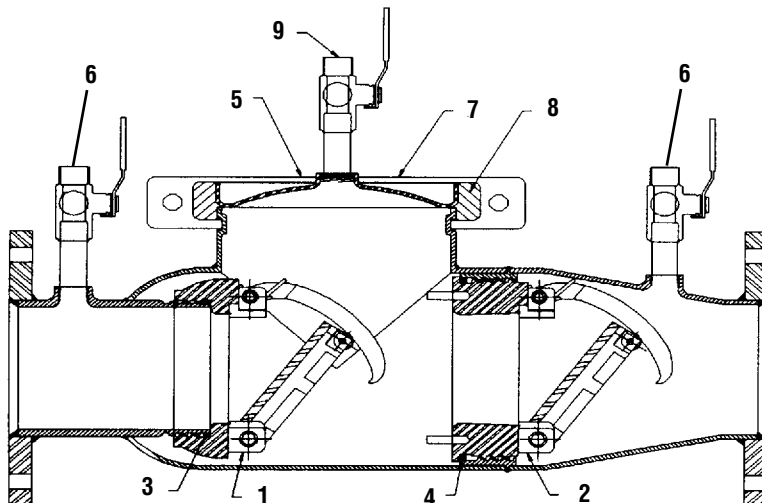

Maintenance Instructions

NOTE: Ames assemblies require minimum maintenance. All assemblies must be retested once maintenance has been performed. Before servicing be certain shutoff valves are closed.

1. Shut down water system and lock out system if possible. Slowly open all ball valves to relieve air and water pressure. Loosen bolts on groove coupler and remove groove coupler and cover plate from valve body.
2. Remove #1 Cam-Check assembly by using your hands to unscrew (turn counter clockwise) Cam-Check and remove through top access port. Do not use Cam Arm as a handle to unscrew Cam-Check. If Cam-Check cannot be loosened by hand, insert a long screwdriver between valve body and Cam-Check (see figure 3). Slowly apply pressure against the Cam-Check until loosened. Finish unscrewing by hand. Unscrew #2 Cam-Check (turn counter clock-wise) by placing a long screwdriver between lugs and applying pressure to loosen #2 Cam-Check. Finish unscrewing by hand.
3. To clean #1 Cam-Check, (except 2 1/2" – 4" DC check) locate the Cam Arm opening stud on the outlet flange of the valve assembly. Slide the Cam Arm over the stud with the check threads facing downward (figure 1). Tighten 1/4" nut on stud to secure cam bar. Slowly pull the assembly outward to open check allowing exposure of the seat and clapper contact area for cleaning. To clean #2 Cam-Check, lift Cam Arm and hold in open position. Raise clapper so that the end of the Cam Arm rests between roller and clapper (figure 2). Thoroughly clean the seat area and clapper sealing surfaces of both Cam-Checks. Rinse Cam-Checks and O-rings thoroughly. Inspect seats, clapper sealing surfaces, Cam Arms, and O-rings for damage. If not damaged, gently close the clapper. If damaged, install a new Cam-Check assembly and/or O-ring.
4. Before reinstallation of Cam-Checks thoroughly clean O-ring groove and lubricate O-ring with FDA approved lubricant. Insert and thread #2 Cam-Check first and then #1 Cam-Check. #2 Cam-Check should be tightened by inserting a long screwdriver between lugs to tighten firmly (see figure 1 on reverse side). Do not over tighten. Tighten #1 Cam-Check firmly by hand only. Replace cover plate, clean groove coupler gasket and groove, replace groove coupler. Close ball valves.

Figure 1

Cam Arm Open Pin

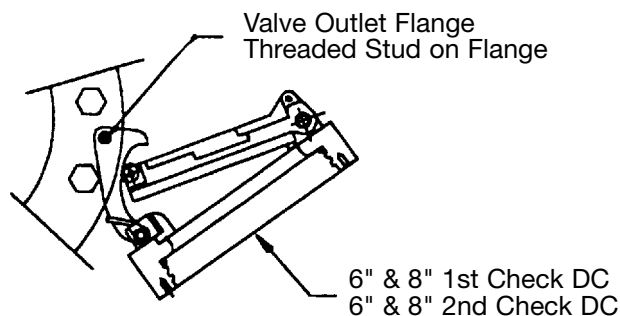
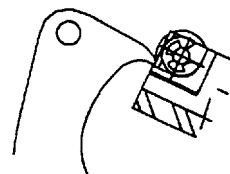
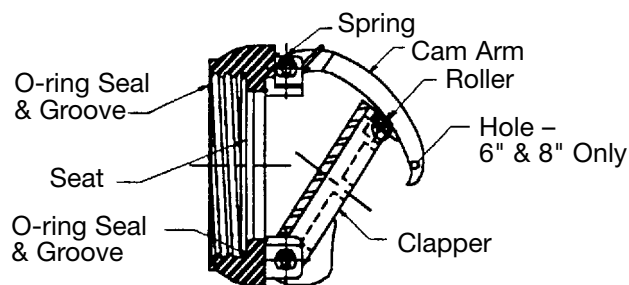

Figure 2

Cleaning Position



#1 Cam-Check 2 1/2" – 6"



#2 Cam-Check DC & RP

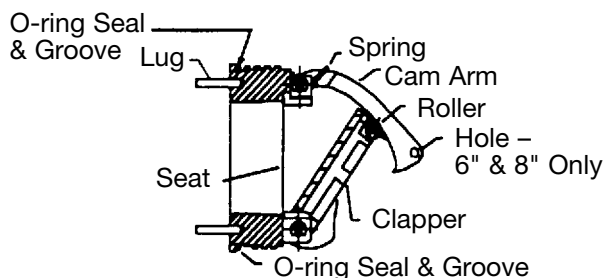
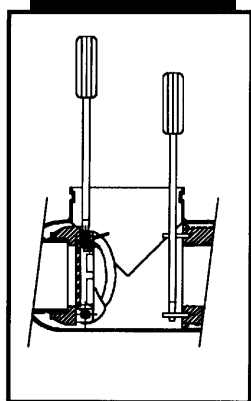

Figure 3



Testing — Double Check Valve Assembly

Test Check Valve No. 1

- Step 1: Ensure shutoff #1 is open, shutoff #2 is closed.
- Step 2: Connect high side hose to test cock #3, low side to test cock #2 and open both test cock #2 and test cock #3.
- Step 3: Open valve C, then open A to bleed air from the high side. Close valve A, then open B to bleed low side. Close valve B.
- Step 4: Connect vent hose loosely to test cock #1. Open valve A to vent air from vent hose. Tighten vent hose at test cock #1, open test cock #1.
- Step 5: Close shutoff #1. Slowly loosen hose at test cock #2 until differential gauge rises to 2psi and retighten hose. If the differential reading does not decrease, record check valves as “tight”.

Test Check Valve No. 2

- Step 1: Move the high side hose to test cock #4, low side to test cock #3 and open both test cock #3 and test cock #4. Remove vent hose from test cock #1, open shutoff #1.
- Step 2: Open valve C, then open valve A to bleed air from the high side. Close valve A, then open valve B to bleed low side. Close valve B.
- Step 3: Connect vent hose loosely to test cock #1. Open valve A to vent air from the vent hose. Tighten vent hose at test cock #1, open test cock #1.
- Step 4: Close shutoff #1, then slowly loosen hose at test cock #3 until differential gauge rises to 2psi and retighten hose. If the differential reading does not decrease, record check as tight. Remove all hoses and restore valve to original working condition.

Note: The assembly will fail both the first and second check valve tests above, if shutoff #2 leaks excessively. To test for a leaky #2 shutoff, use the following procedure.

Test for Leaky No. 2 Shutoff

- Step 1: Connect the high side to test cock #1, low side to test cock #4. Open test cock #1 and test cock #4. Close shutoffs #1 and #2.
- Step 2: Close valve C. Open valve A, then open valve B ½ turn, loosen hose at test cock #4 to remove air. Retighten hose.
- Step 3: If the differential gauge rises above 0, there is excessive leakage at shutoff #2 and it must be replaced to test the assembly.

Note: Product information is subject to change without notice and supersedes all previous publications.

Ball Type Test Valves

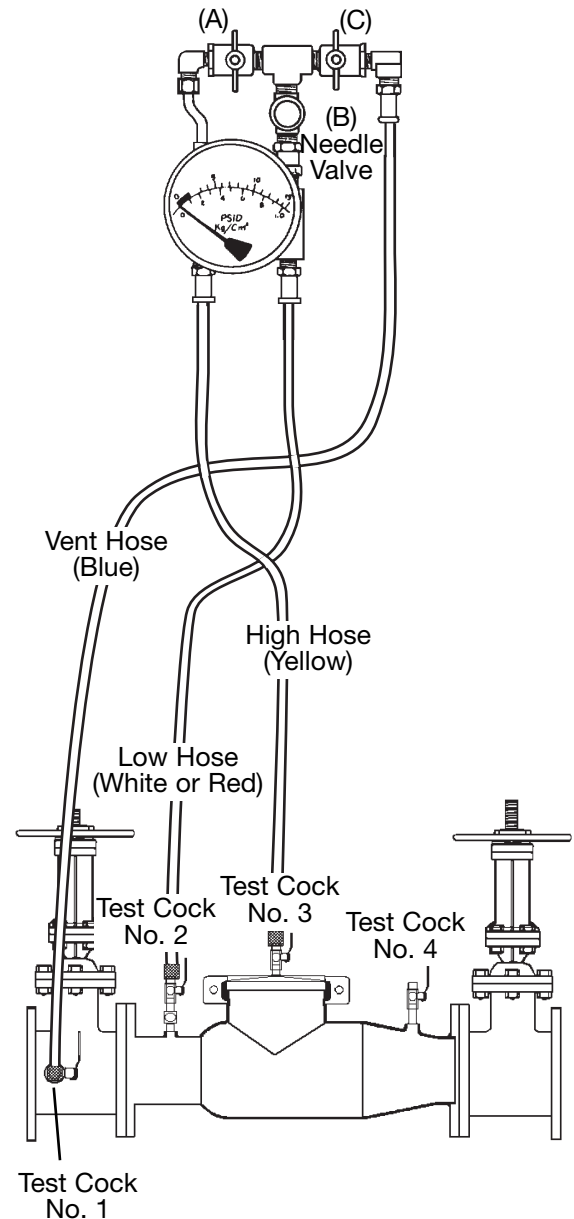

A Division of Watts Industries

www.amesfirewater.com

