

Double Check Detector Assembly

Sizes: 2" (65mm)

- Installation
- Service
- Repair Kits
- Maintenance

For other repair kits and service parts, send for Ames Repair Parts Price List, PL-A-RP-BPD.

For technical assistance, contact your local Ames representative.

IMPORTANT: Inquire with governing authorities for local installation requirements.

NOTE: For Australia and New Zealand, line strainers should be installed between the upstream shutoff valve and the inlet of the backflow preventer.

Its important that this assembly be tested periodically in compliance with local codes, but at least once per year or more as service conditions warrant. If installed on a fire sprinkler system, all mechanical checks, such as alarm checks and backflow preventers, should be flow tested and inspected internally in accordance with NFPA 13 and NFPA 25.

Limited Warranty: Ames Company warrants each product to be free from defects in material and workmanship under normal usage for a period of one year from the date of original shipment. In the event of such defects within the warranty period, the Company will, at its option, replace or recondition the product without charge. This shall constitute the sole and exclusive remedy for breach of warranty, and the Company shall not be responsible for any incidental, special or consequential damages, including without limitation, lost profits or the cost of repairing or

replacing other property which is damaged if this product does not work properly, other costs resulting from labor charges, delays, vandalism, negligence, fouling caused by foreign material, damage from adverse water conditions, chemical, or any other circumstances over which the Company has no control. This warranty shall be invalidated by any abuse, misuse, misapplication or improper installation of the product. **THIS WARRANTY IS IN LIEU OF ALL OTHER WARRANTIES, EXPRESS OR IMPLIED, INCLUDING ANY IMPLIED WARRANTIES OF MERCHANTABILITY OR FITNESS FOR A PARTICULAR PURPOSE.** Any implied warranties that are imposed by law are limited in duration to one year.

Some States do not allow limitations on how long an implied warranty lasts, and some States do not allow the exclusion or limitation of incidental or consequential damages. Therefore the above limitations may not apply to you. This Limited Warranty gives you specific legal rights, and you may have other rights that vary from State to State. You should consult applicable state laws to determine your rights.

CALIFORNIA PROPOSITION 65 WARNING

WARNING: This product contains chemicals known to the State of California to cause cancer and birth defects or other reproductive harm. (Installer: California law requires that this warning be given to the consumer.)

For more information: www.wattsind.com/prop65

Installation Note: The flange gasket bolts for the gate valves should be retightened during installation as the bolts may have loosened due to storage and shipping.

A Division of Watts Industries

875 National Drive • Suite #107 • Sacramento, CA 95834 • Phone: 916-928-0123 • Fax: 916-928-9333

www.amesfirewater.com



Basic Installation Instructions

Indoors Installation

Ames Model 3000B may be installed in either a vertical or horizontal position. Pipe lines should be thoroughly flushed to remove foreign material before installing the unit. A strainer should be installed as shown, ahead of backflow preventer to prevent disc from unnecessary fouling. Install valve in the line with arrow on valve body pointing in the direction of flow.

For indoor installations, it is important that the valve be easily accessible to facilitate testing and servicing. Do not install in a concealed location.

CAUTION: Do not install with strainer when backflow preventer is used on seldom-used water lines which are called upon during emergencies, such as fire sprinkler lines, etc.

It is important that Model 3000B be tested periodically in compliance with local codes, but at least once a year or more often depending upon system conditions.

Note Fire Protection System Installations: The National Fire Protection Agency (NFPA) Guidelines require a confirming flow test to be conducted whenever a "main line" valve such as the shutoff valves or a backflow assembly have been operated. Certified testers of backflow assemblies must conduct this test. The trim valves of the detector meter bypass line, on assemblies so equipped, should be shut off during the confirming flow test. When the test is completed the trim valves must be returned to a fully open position.

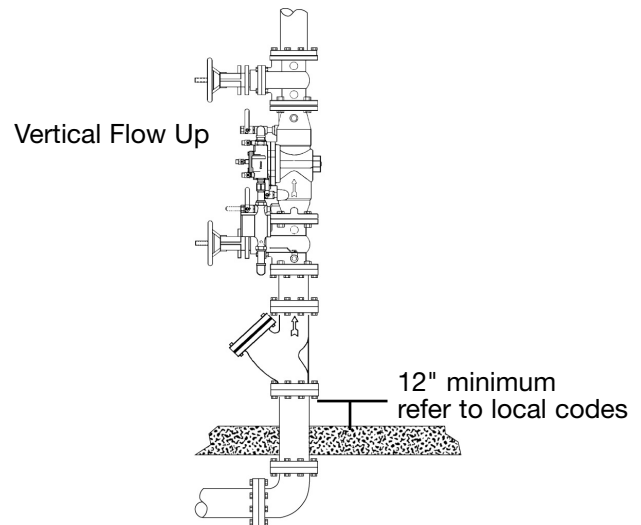
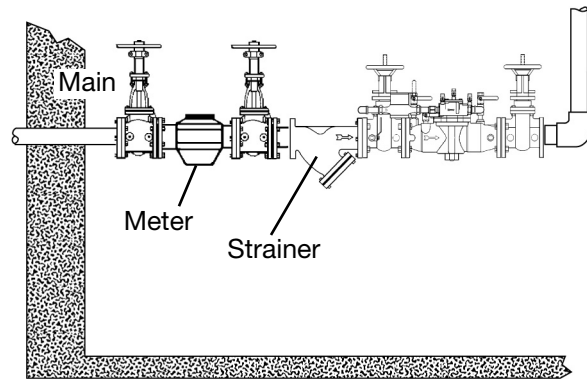

Outside Installation — Above Ground

In areas where freezing conditions do not occur, Model 3000B can be installed outside of a building. The most satisfactory installation is above ground and should be installed in this manner whenever possible.

In an area where freezing conditions can occur, Model 3000B should be installed above ground in an insulated enclosure.

Annual inspection of all water system safety and control valves is required and necessary. Regular inspection, testing and cleaning assures maximum life and proper product function.

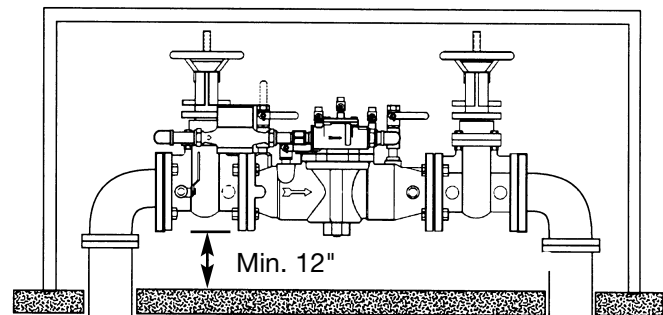

Maintenance Instructions

Servicing the First and Second Check Valves

1. Remove cover bolts and cover.
2. Remove the retainer from the body bore. The check valve modules can now be removed from the valve by hand or with a screwdriver.
3. The check seats are attached to the cage with a bayonet type locking arrangement. Holding the cage in one hand, push the seat inward and rotate counter-clockwise against the cage. The seat, spring cage, spring and disc assembly are now individual components.
4. The disc assembly may now be cleaned and reassemble or depending on its condition, may be discarded and replaced with a new assembly from the repair kit. O-rings should be cleaned or replaced as necessary.
5. Reassemble the check valve modules. Check modules are installed in the valve body with the seats facing the valve inlet. The modules must be securely in place before the retainer can be replaced.

NOTE: No special tools required to service Model 3000B.

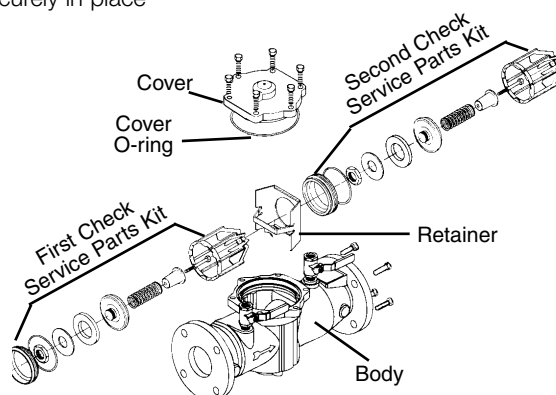
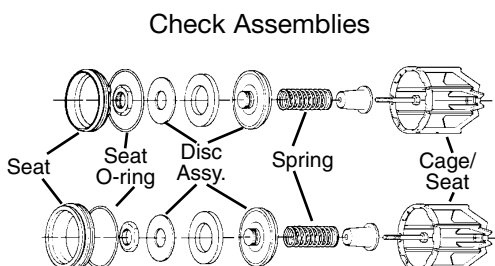

Replacement Parts

When ordering, specify Ordering Code, Kit Number and Valve Size.

First Check Kit

Ordering Code	Kit No.	Size
7016200	ARK 3000B CK1	2"

Kit includes: **Seat, Seat O-ring, Disc assembly, Spring, Spring retainer, Check Cage and Cover O-ring.**

Second Check Kit

7016201	ARK 3000B CK2	2"
---------	---------------	----

Kit includes: **Seat, Seat O-ring, Disc assembly, Spring, Spring retainer, Check cage and Cover O-ring.**

First and Second Check Rubber Parts

7016202	ARK 3000B RT	2"
---------	--------------	----

Kit includes: **Two seat discs, Two seat O-rings, Two Cover O-rings.**

Cover Kit

Ordering Code	Kit No.	Size
7016203	ARK 3000B C	2"

Kit includes: **Cover, Cover O-ring.**

Seat Kit

7016204	ARK 3000B S1	2"
7016205	ARK 3000B S2	2"

Kit includes: **Seat, Seat O-ring.**

"Use only original equipment manufactured parts to protect the validated warranty."

Testing — Double Check Valve Assembly

Test Check Valve No. 1

- Step 1: Ensure shutoff #1 is open, shutoff #2 is closed.
- Step 2: Connect high side hose to test cock #3, low side to test cock #2 and open both test cock #2 and test cock #3.
- Step 3: Open valve C, then open A to bleed air from the high side. Close valve A, then open B to bleed low side. Close valve B.
- Step 4: Connect vent hose loosely to test cock #1. Open valve A to vent air from vent hose. Tighten vent hose at test cock #1, open test cock #1.
- Step 5: Close shutoff #1. Slowly loosen hose at test cock #2 until differential gauge rises to 2psi and retighten hose. If the differential reading does not decrease, record check valves as “tight”.

Test Check Valve No. 2

- Step 1: Move the high side hose to test cock #4, low side to test cock #3 and open both test cock #3 and test cock #4. Remove vent hose from test cock #1, open shutoff #1.
- Step 2: Open valve C, then open valve A to bleed air from the high side. Close valve A, then open valve B to bleed low side. Close valve B.
- Step 3: Connect vent hose loosely to test cock #1. Open valve A to vent air from the vent hose. Tighten vent hose at test cock #1, open test cock #1.
- Step 4: Close shutoff #1, then slowly loosen hose at test cock #3 until differential gauge rises to 2psi and retighten hose. If the differential reading does not decrease, record check as tight. Remove all hoses and restore valve to original working condition.

Note: The assembly will fail both the first and second check valve tests above, if shutoff #2 leaks excessively. To test for a leaky #2 shutoff, use the following procedure.

Test for Leaky No. 2 Shutoff

- Step 1: Connect the high side to test cock #1, low side to test cock #4. Open test cock #1 and test cock #4. Close shutoffs #1 and #2.
- Step 2: Close valve C. Open valve A, then open valve B ½ turn, loosen hose at test cock #4 to remove air. Retighten hose.
- Step 3: If the differential gauge rises above 0, there is excessive leakage at shutoff #2 and it must be replaced to test the assembly.

Note: Product information is subject to change without notice and supersedes all previous publications.

