

## Detector Check Valves

Sizes: 4" – 10" (100 – 250mm)

- Installation
- Service
- Repair Kits
- Maintenance

For other repair kits and service parts, send for Ames Repair Parts Price List, PL-A-RP-BPD.

For technical assistance, contact your local Ames representative.

**IMPORTANT:** Inquire with governing authorities for local installation requirements.

**NOTE:** For Australia and New Zealand, line strainers should be installed between the upstream shutoff valve and the inlet of the backflow preventer.

Its important that this device be tested periodically in compliance with local codes, but at least once per year or more as service conditions warrant. If installed on a fire sprinkler system, all mechanical checks, such as alarm checks and backflow preventers, should be flow tested and inspected internally in accordance with NFPA 13 and NFPA 25.

**Limited Warranty:** Ames Company warrants each product to be free from defects in material and workmanship under normal usage for a period of one year from the date of original shipment. In the event of such defects within the warranty period, the Company will, at its option, replace or recondition the product without charge. This shall constitute the sole and exclusive remedy for breach of warranty, and the Company shall not be responsible for any incidental, special or consequential damages, including without limitation, lost profits or the cost of repairing or

replacing other property which is damaged if this product does not work properly, other costs resulting from labor charges, delays, vandalism, negligence, fouling caused by foreign material, damage from adverse water conditions, chemical, or any other circumstances over which the Company has no control. This warranty shall be invalidated by any abuse, misuse, misapplication or improper installation of the product. **THIS WARRANTY IS IN LIEU OF ALL OTHER WARRANTIES, EXPRESS OR IMPLIED, INCLUDING ANY IMPLIED WARRANTIES OF MERCHANTABILITY OR FITNESS FOR A PARTICULAR PURPOSE.** Any implied warranties that are imposed by law are limited in duration to one year.

Some States do not allow limitations on how long an implied warranty lasts, and some States do not allow the exclusion or limitation of incidental or consequential damages. Therefore the above limitations may not apply to you. This Limited Warranty gives you specific legal rights, and you may have other rights that vary from State to State. You should consult applicable state laws to determine your rights.

### CALIFORNIA PROPOSITION 65 WARNING

**WARNING:** This product contains chemicals known to the State of California to cause cancer and birth defects or other reproductive harm. (Installer: California law requires that this warning be given to the consumer.)

For more information: [www.wattsind.com/prop65](http://www.wattsind.com/prop65)

# Basic Installation Instructions

## Installation

- A. The installation and maintenance of any Ames Detector Check Valve should be performed by a qualified licensed technician. Failure to do so may result in a malfunctioning assembly. All instructions should be read thoroughly by the technician before installation or performing any maintenance on the assembly.
- B. Before installing an Ames Detector Check Valve, flush the lines thoroughly to remove all debris, chips and other foreign objects. Failure to do so may make the assembly inoperable.

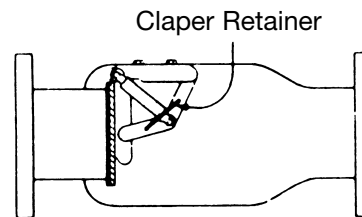
## Removal & Replacement of Knuckle Joint Assembly

### (Internal Closing Assembly)

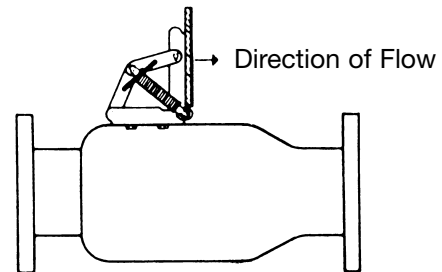
1. Shut down water system and lock out if possible.
2. Loosen vent screw in lid slowly to ensure system pressure has been relieved.
3. Loosen and remove all inspection port bolts and remove lid and gasket from valve.
4. Install proper size clapper retainer clip (see figure 1). Be sure clip is pushed to within  $\frac{1}{2}$ " of linkage.
5. Loosen equally the two knuckle joint mounting bolts, until assembly is free. As bolts are loosened linkage will release slightly and lock clapper retainer clip in place.
6. Remove knuckle joint from body assuring clapper retainer clip is not disturbed, as preloaded knuckle joint springs have considerable tension in this position.
7. Bolt the knuckle joint to the outside of the body using the new  $\frac{3}{8}$ " bolts supplied with the new knuckle joint (see figure 2).
8. Push on clapper plate to release clapper retainer clip, remove and slowly release tension on clapper. Unbolt knuckle joint assembly from outside of body.
9. Bolt replacement knuckle joint assembly to body.
10. Push on clapper plate to extend springs and install clapper retainer clip, making sure springs are seated on pins. Unbolt knuckle joint assembly from body bolt hole.
11. Insert two new  $\frac{3}{8}$ " mounting bolts and washers through mounting holes in body. Position knuckle joint in place inside body, and finger tighten both bolts.
12. Torque knuckle joint mounting bolts to 60 inch-pounds.  
**Remove clapper retainer clip.**
13. Replace lid and new gasket.

**Attention Installer: After installation, please leave this Instruction Sheet for occupant's information.**

**Figure 1**

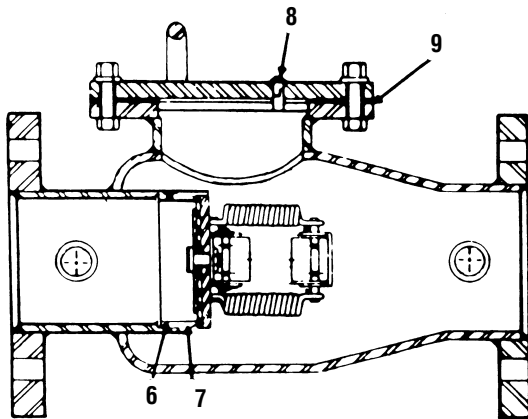


**Figure 2**

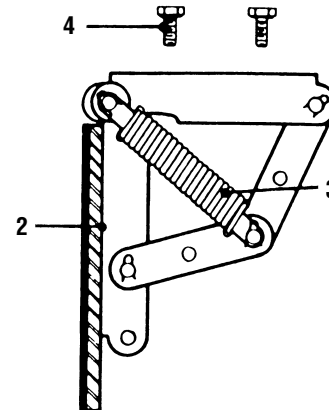


# Repair Parts

Housing Half Section



Knuckle Joint Assembly 1



Item #	Description	Qty.	Ames Part Numbers			
			4"	6"	8"	10"
1.	Knuckle Joint Assembly (Complete Unit)	1	7015550	7015551	7015552	7015552
2.	Clapper Plate with Attached Link	1	7011411	7011412	7011413	7011413
3.	Spring		7011320	7011128	7011323	7011323
	4", 6" Knuckle Joint Assembly	2 Springs Req'd				
	8", 10" Knuckle Joint Assembly	3 Springs Req'd				
4.	3/8" Stainless Steel Bolts	2	7014619	7014619	7014619	7014619
5.	Washer (not shown)	2	7014585	7014585	7014585	7014585
6.	Bronze Seat (Replaceable in line)	1	7011160	7011162	7011163	7011163
7.	Seat O-ring	1	7011161	A300704	A300706	A300706
8.	Vent Screw	1	7011133	7011133	7011133	7011133
9.	Bonnet Gasket	1	7011123	7011124	7011125	7011125
10.	Clapper Retainer Clip (not shown)	1	7013911	7013912	7013913	7013913

## For Technical Assistance Call Your Authorized Ames Agent.

			Telephone #	Fax #
	<b>HEADQUARTERS:</b> Ames Co.	875 National Dr., Suite. 107, Sacramento, CA 95834	916 928-0123	916 928-9333
<b>North East</b>	Vernon Bitzer Associates, Inc.	138 Railroad Dr., Northampton Ind. Pk., Ivyland, PA 18974	215 953-1400	215 953-1250
	Edwards, Platt & Deely, Inc.	368 Wyandanch Ave., North Babylon, NY 11703	631 253-0600	631 253-0303
	Edwards, Platt & Deely, Inc.	271 Royal Ave., Hawthorne, NJ 07506	973 427-2898	973 427-4246
	The Joyce Agency, Inc.	8442 Alban Rd., Springfield, VA 22150	703 866-3111	703 866-2332
	W. P. Haney Co., Inc.	51 Norfolk Ave., South Easton, MA 02375	508 238-2030	508 238-8353
	WMS Sales, Inc. (Main office)	9580 County Rd., Clarence Center, NY 14032	716 741-9575	716 741-4810
	WMS Sales, Inc.	47 Carousel Lane, Baldwinville, NY 13027	315 635-6596	315 635-6891
	WMS Sales, Inc.	18 McMillen Place, Delmar, NY 12054	518 475-1017	518 475-9583
WMS Sales, Inc.	56 Winchester Dr., Fairport, NY 14450	716 223-7980	716 223-7980	
<b>South East</b>	Billingsley & Associates, Inc.	2728 Crestview Ave., Kenner, LA 70062-4829	504 602-8100	504 602-8106
	Billingsley & Associates, Inc.	478 Cheyenne Lane, Madison, MS 39110	601 856-7565	601 856-8390
	Smith & Stevenson Co., Inc.	4935 Chastain Ave., Charlotte, NC 28217	704 525-3388	704 525-6749
	Mid-America Marketing, Inc.	1364 Foster Avenue, Nashville, TN 37210	615 259-9944	615 259-5111
	Mid-America Marketing, Inc.	5466 Old Hwy. 78, Memphis, TN 38118	901 795-0045	901 795-0394
	RMI Wager Company	Glenfield Bus. Ctr., 2535 Mechanicsville Tpk., Richmond, VA 23223 702-B Industry Rd., Longwood, FL 32750	804 643-7355 407 834-4667	804 643-7380 407 831-0091
<b>South Central</b>	Hugh M. Cunningham, Inc.	13755 Benchmark, Dallas, TX 75234	972 888-3800	972 888-3838
	Mack McClain & Associates	11132 south Towne Squire, Suite 202, St. Louis, MO 63123	314 771-3699	314 771-3535
	Mack McClain & Associates, Inc.	1537 Ohio St., Des Moines, IA 50314	515 288-0184	515 288-5049
	Mack McClain & Associates, Inc. Pro-Spec, Inc.	15090 West 116th St., Olathe, KS 66062 P.O. Box 472226, Tulsa, OK 74147-2226	913 339-6677 918 461-0066	913 339-9518 918 461-0105
<b>North Central</b>	Associated Independent Marketing	1606 Commerce Dr., Sun Prairie, WI 53590	608 837-5005	608 837-2368
	HydroSource	8182 Chagrin Rd., Chagrin Falls, OH 44023	440 247-9150	440 247-6719
	Mid-Continent Marketing Services Ltd.	1724 Armitage Ct., Addison, IL 60101	630 953-1211	630 953-1067
<b>South West</b>	Cisco	1623 N. Leslie Way, Orange, CA 92867	714 921-9228	714 921-0442
	Phoenix Marketing, Ltd.	3322 Columbia Dr., NE, Albuquerque, NM 87107	505 883-7100	505 883-7101
	P I R Sales, Inc.	3050 North San Marcos Place, Chandler, AZ 85225	480 892-6000	480 892-6096
	Preferred Sales	31177 Wiegman Road, Hayward, CA 94544	510 487-9755	510 476-1595
<b>North West</b>	Delco Sales, Inc.	111 Sand Island Access Rd., Unit I-10, Honolulu, HI 96819	808 842-7900	808 842-9265
	Fanning & Associates, Inc.	6765 Franklin St., Denver, CO 80229-7111 (Montana Only)	303 289-4191	303 286-9069
	Hollabaugh Brothers & Associates	6915 South 194th St., Kent, WA 98032	253 867-5040	253 867-5055
	Hollabaugh Brothers & Associates	3028 S.E. 17th Ave., Portland, OR 97202	503 238-0313	503 235-2824
	Rep Masters, Inc.	6201 East 42nd Ave., Suite 100, Denver, CO 80216	303 376-1770	303 376-1773
	Soderholm & Associates, Inc.	7150 143rd Ave. N.W., Anoka, MN 55303	763 427-9635	763 427-5665
<b>CANADA</b>	Watts Industries (Canada) Inc. (Watts Regulator Co. Division)	5435 North Service Road, Burlington, Ontario L7L 5H7	905 332-4090	905 332-7068
	Hydro-Mechanical Sales Ltd.	3700 Joseph Howe Dr., Ste. 1 Halifax, Nova Scotia B3L 4H7	902 443-2274	902 443-2275
	Hydro-Mechanical Sales Ltd.	297 Collishaw St., Ste. 7 (shipping) Moncton, New Brunswick E1C 9R2	506 859-1107	506 859-2424
	Hydro-Mechanical Sales Ltd.	85 Toit Rd., St. Phillips, Newfoundland A1B 3M7	709 895-0090	709 895-0091
	Le Groupe B.G.T. Inc.	2800 Rue Dalton, Ste. 3, Parc Colbert, St-Foy, Quebec G1P 3S4	418 657-2800	418 657-2700
	Le Groupe B.G.T. Inc.	140 Rue Merizzi, Ville St. Laurent, Quebec H4T 1S4	514 341-9010	514 341-4464
	Walmar Mechanical Sales	24 Gurdwara Re., Nepean, Ontario K2E8B5	613 225-9774	613 225-0673
	Mar-Win Agencies St.	1123 Empress St., Winnipeg, Manitoba R3E 3H1	204 775-8194	204 786-8016
	Palsler Enterprises, Ltd.	1885 Blue Heron Dr., #4, London, Ontario N6H 5L9	519 471-9382	519 471-1049
	Northern Mechanical Sales	P.O. Box 280 (mailing) 163 Pine St. (shipping), Garson, Ontario P3L 1S6	705 693-2715	705 693-4394
	RAM Mechanical Marketing	1301 Winnipeg St., Regina, Saskatchewan S4R 1K2	306 525-1986	306 525-0809
	RAM Mechanical Marketing	#13-1100 7th Ave. N., Saskatoon, Saskatchewan S7K 2V9	306 244-6622	306 244-0807
	D.C. Sales Ltd.	10-6130 4th St. S.E., Calgary, Alberta T2H 2A6	403 253-6808	403 259-8331
	D.C. Sales Ltd.	11420 142 Street, Edmonton, Alberta T6M 1V1	780 496-9495	780 496-9621
	Sierra Sales Ltd.	6450 Roberts St., Ste. 170, Burnaby, BC V5G 4E1	604 298-9593	604 298-9917



A Division of Watts Industries

www.amesfirewater.com



875 National Drive • Suite #107 • Sacramento, CA 95834 • Phone: 916-928-0123 • Fax: 916-928-9333