

Series 009

Reduced Pressure Zone Assemblies

Sizes: 1/4" – 3"

- Installation
- Service
- Repair Kits
- Maintenance

For field testing procedure, send for IS-TK-DL, IS-TK-9A, IS-TK-99E AND IS-TK-99D.

For other repair kits and service parts, send for PL-RP-BPD.

For technical assistance, contact your local Watts representative.

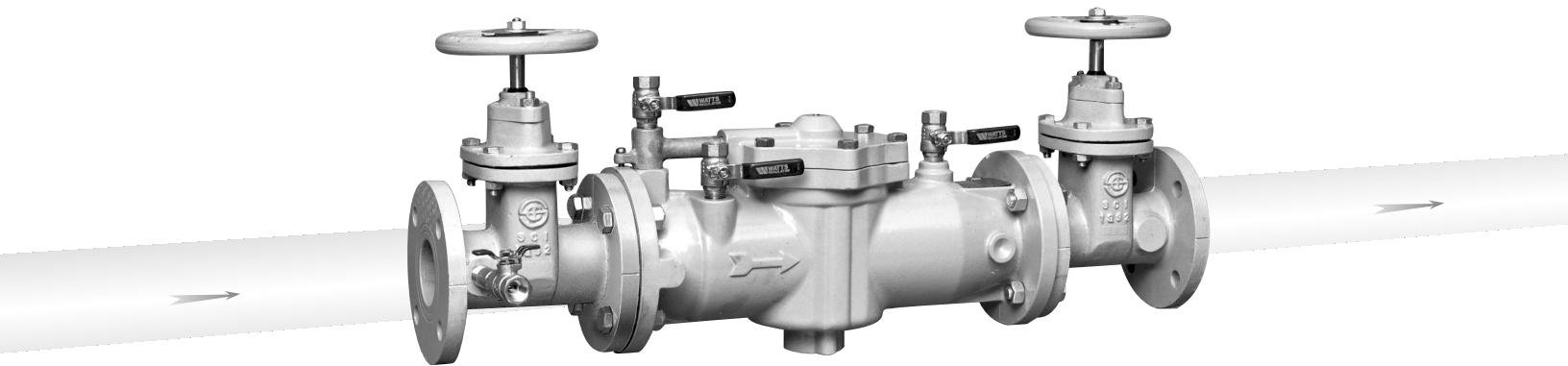

3" 009NRS

CALIFORNIA PROPOSITION 65 WARNING

WARNING: This product contains chemicals known to the State of California to cause cancer and birth defects or other reproductive harm. (Installer: California law requires that this warning be given to the consumer.)

For more information: www.wattsind.com/prop65

IMPORTANT: Inquire with governing authorities for local installation requirements.

NOTE: For Australia and New Zealand: Pipeline strainers should be installed between the upstream shutoff valve and the inlet of the backflow preventer.

Its important that this assembly be tested periodically in compliance with local codes, but at least once per year or more as service conditions warrant. If installed on a fire sprinkler system, all mechanical checks, such as alarm checks and backflow preventers, should be flow tested and inspected internally in accordance with NFPA 13 and NFPA 25.

Limited Warranty: Watts Regulator Company warrants each product to be free from defects in material and workmanship under normal usage for a period of one year from the date of original shipment. In the event of such defects within the warranty period, the Company will, at its option, replace or recondition the product without charge. This shall constitute the sole and exclusive remedy for breach of warranty, and the Company shall not be responsible for any incidental, special or consequential damages, including without limitation, lost profits or the cost of repairing or replacing other property which is damaged if this product does not work properly, other costs resulting from labor charges, delays, vandalism, negligence, fouling caused by foreign material, damage from adverse water conditions, chemical, or any other circumstances over which the Company has no control. This warranty shall be invalidated by any abuse, misuse, misapplication or improper installation of the product. **THIS WARRANTY IS IN LIEU OF ALL OTHER WARRANTIES, EXPRESS OR IMPLIED, INCLUDING ANY IMPLIED WARRANTIES OF MERCHANTABILITY OR FITNESS FOR A PARTICULAR PURPOSE.** Any implied warranties that are imposed by law are limited in duration to one year.

Some States do not allow limitations on how long an implied warranty lasts, and some States do not allow the exclusion or limitation of incidental or consequential damages. Therefore the above limitations may not apply to you. This Limited Warranty gives you specific legal rights, and you may have other rights that vary from State to State. You should consult applicable state laws to determine your rights.



Installation Instructions

Indoors – Figure 1

For indoor installations, it is important that the assembly be easily accessible to facilitate testing and servicing. If it is located in a line close to a wall, be sure the test cocks are easily accessible. A drain line and air gap (see literature ES-AG/EL/TC) should be piped from the relief valve connection as shown, where evidence of discharge will be clearly visible and so that water damage will not occur. Therefore, never install in concealed locations.

Outside – Figure 2

In an area where freezing conditions do not occur, Series 009 can be installed outside. The most satisfactory installation is above ground and should be installed in this manner whenever possible.

In an area where freezing conditions can occur, Series 009 should be installed above ground in an insulated enclosure. Series 009 must be installed in an accessible location to facilitate testing and servicing. A discharge line should be piped from the air gap at the relief valve connection making sure that there is adequate drainage. Never pipe the discharge line directly into a drainage ditch, sewer or sump. Series 009 should never be installed where any part of the unit could become submerged in standing water.

It is generally recommended that backflow preventers never be placed in pits unless absolutely necessary and then only when approved by local codes. In such cases, a modified pit installation is preferred.

Parallel – Figure 3

Two or more smaller size assemblies can be piped in parallel (when approved) to serve a large supply pipe main. This type of installation is employed where increased capacity is needed beyond that provided by a single valve and permits testing or servicing of an individual valve without shutting down the complete line.

The number of assemblies used in parallel should be determined by the engineer's judgement based on the operating conditions of a specific installation.

For parallel valve installations, the total capacity of the assemblies should equal or exceed that required by the system.

Annual inspection of all water system safety and control valves is required and necessary. Regular inspection, testing and cleaning assures maximum life and proper product function.

Figure 1

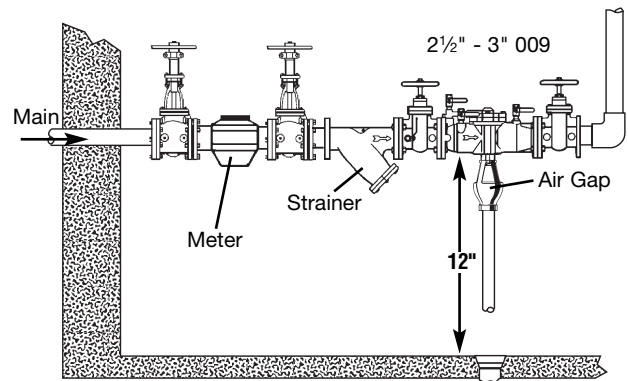
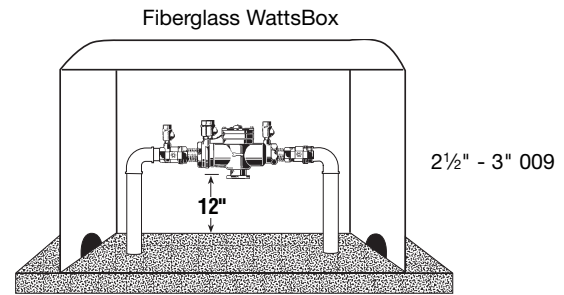
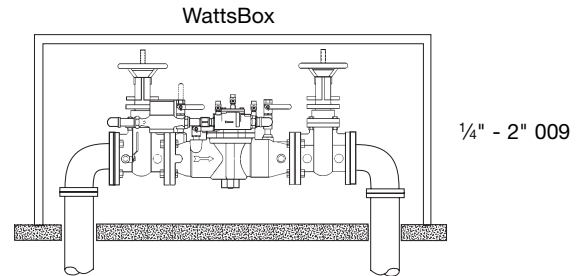

Figure 2



Now available, WattsBox Insulated Enclosures, for more information, send for literature ES-WB.



Now available, WattsBox Insulated Enclosures, for more information, send for literature ES-WB.

Figure 3

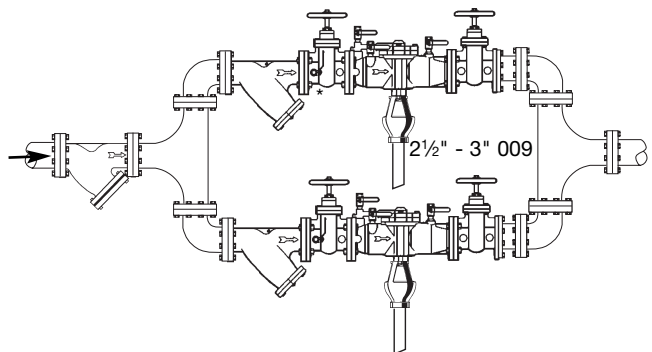

Installation Instructions

Note: Shutoff Valves: When shutoff valves are removed and reassembly is necessary, the shutoff valve with the test cock is to be mounted on the inlet side of the backflow preventer.

- A. The 009 should always be installed in an accessible location to facilitate testing and servicing (See page 2). **Check the state and local codes to ensure that the backflow preventer is installed in compliance, such as the proper height above the ground.**
- B. We recommend a strainer be installed ahead of 009 series assemblies to protect the internal components from unnecessary fouling.

Caution: Do not install with strainer when backflow preventer is used on seldom-used water lines which are called upon only during emergencies, such as fire sprinkler lines.

Start Up: The downstream shutoff should be closed. Open upstream slowly and fill valve. When valve is filled, open the downstream shutoff slowly and fill the water supply system. This is necessary to avoid water hammer or shock damage.

- C. Water discharge from the relief valve should be vented in accordance with code requirements. The relief valve should never be solidly piped into a drainage ditch, sewer or sump. The discharge should be terminated approximately 12" above the ground or through an air gap piped to a floor drain.

NOTE: Relief Valve Discharge Rates

The installation of an air gap with the drain line terminating above a floor drain will handle any normal discharge or nuisance spitting through the relief valve. However, floor drain size may need to be designed to prevent water damage caused by a catastrophic failure condition. Please refer to Figure No. 1 for maximum relief valve discharge rates, size and capacity of typical floor drains.

NOTE: Do not reduce the size of the drain line from the air gap fitting. Pipe full line size.

- D. After initial installation, a discharge from the relief valve opening may occur due to inadequate initial flushing of pipe lines to eliminate dirt and pipe compounds. If flushing will not clear, remove the first check valve and clean thoroughly.

NOTE: Periodic relief valve discharge may occur on dead end service applications, such as boiler feed lines or cooling tower makeup lines due to fluctuating supply pressure during a static or no flow condition. To avoid this discharge, install a spring-loaded rubber seated check valve ahead of the backflow assembly to "lock-in" the downstream pressure.

- E. Backflow preventers should never be placed in pits unless absolutely necessary and then only when and as approved by local codes. In such cases, provision should be made to always vent above flood level or for a pit drain to ensure an adequate air gap below the relief port.
- F. It is important that Series 009 backflow preventers be inspected periodically for any discharge from the relief valve which will provide a visual indication of need for cleaning or repair of check valves. Also testing for proper operation of the device should be made periodically in compliance with local codes, but at least once a year or more often, depending upon system conditions.

Relief vent will discharge water when, during no-flow periods, (1) the first check valve is fouled or (2) the inlet pressure to the device drops sufficiently due to upstream pressure fluctuations to affect the required operating differential between the inlet pressure and reduced pressure zone. Other wise, such relief (spitting) can occur when the second check is fouled during emergency backflow or resulting from a water hammer condition. For troubleshooting guide send for S-TSG.

NOTE: Special considerations are necessary when testing assemblies installed on Fire Prevention Systems.

Fire Protection System Installations: The National Fire protection Agency (NFPA) Guidelines require a confirming flow test be conducted whenever a "main line" valve such as the shutoff valves or a backflow assembly have been operated. Certified testers of backflow assemblies must conduct this confirming test.

Figure 1

Relief Valve Discharge Rates

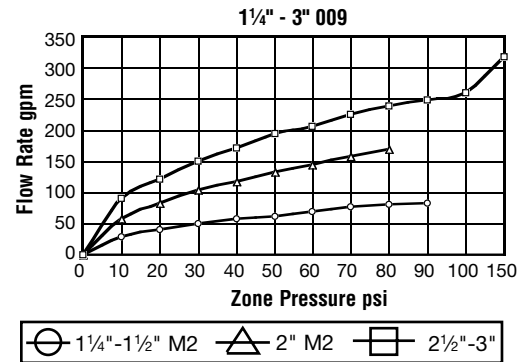
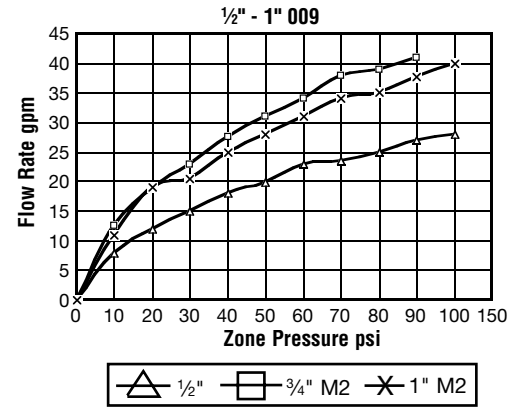

TYPICAL FLOW RATES AS SIZED BY FLOOR DRAIN MANUFACTURERS:

2"	55 GPM	5"	350 GPM
3"	112 GPM	6"	450 GPM
4"	170 GPM	8"	760 GPM

Servicing the Relief Valve

1/4" - 2"

1. Remove the relief valve cover bolts while holding the cover down.
2. Lift the cover straight off. The stem and diaphragm assembly will normally remain with the cover as it is removed. The relief valve spring will be free inside the body at this point.
3. The relief valve seat is located at the bottom of the body bore, and can be removed, if necessary, for cleaning. The disc can be cleaned without disassembly or the relief valve module. If it is determined that the relief valve diaphragm and/or disc should be replaced, the relief valve module can be readily disassembled without the use of special tools.
Note: the disc rubber is molded into the disc holder and is supplied as a disc holder assembly.
4. To re-assemble the relief valve, press the seat firmly into place in the body, center the spring on the seat, and insert the cover and relief valve module as a unit straight into the bore. Press down on the cover to assure proper alignment. Insert and tighten bolts.

Caution: If cover will not press flat against body, stem assembly is crooked and damage can result. Re-align stem and cover before bolts are inserted.

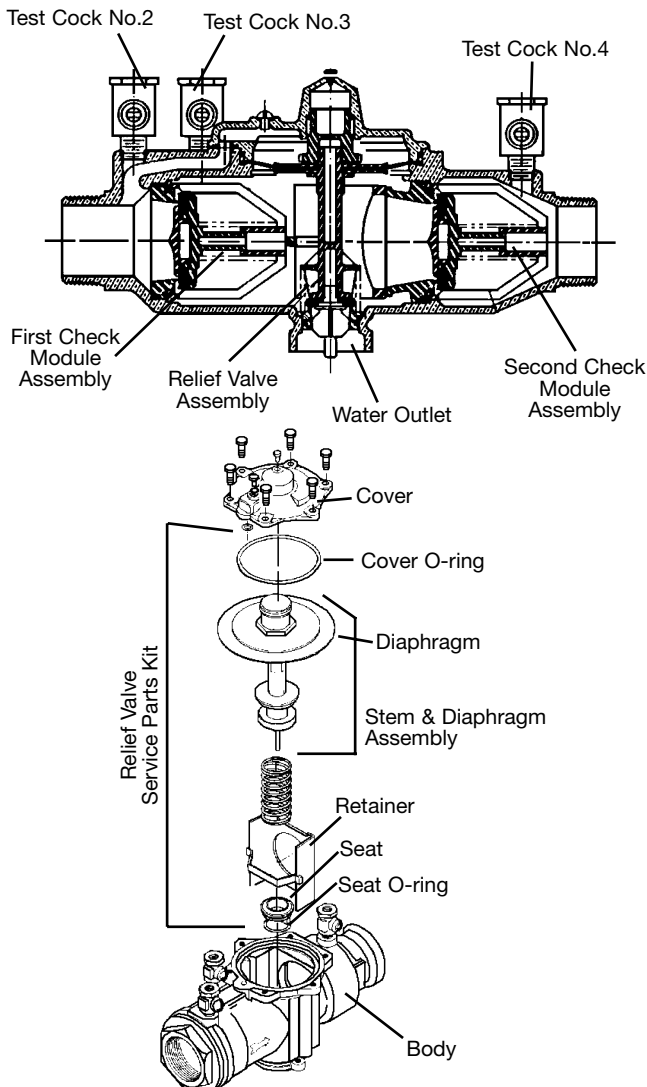

Replacement Parts — 1/4" - 2"

When ordering, specify Ordering Code, Kit number and Valve Size.

1/4" - 1"

ORDERING CODE	KIT NO.	SIZE
---------------	---------	------

Relief Valve Kits:

0887294	RK 009 VT	1/4", 3/8", 1/2"
0887509	RK SS009 VT	1/2"
0887002	RK 009M2 VT	3/4"
0887520	RK SS009M2/M3 VT	1/4" - 3/4"
0888524	RK 009M3 VT	3/4"
0887015	RK 009 VT	3/4" - 1"
0887503	RK SS009 VT	1"
0887785	RK 009M2 VT	1"

Kit consists of: Seat, Seat O-ring, Stem & diaphragm assembly, Stem O-ring, Cover O-ring and RV spring.

Relief Valve Rubber Parts Kits:

0887295	RK 009 RV	1/4", 3/8", 1/2"
0887510	RK SS009 RV	1/2"
0886998	RK 009M2 RV	3/4"
0887519	RK SS009M2/M3 RV	1/4" - 3/4"
0888523	RK 009M3 RV	3/4"
0887181	RK 009 RV	3/4" - 1"
0887529	RK SS009 RV	1"
0887786	RK 009M2 RV	1"

Kit consists of: Diaphragm, Disc assembly, Stem O-rings, Seat O-ring and Cover O-ring.

Total Rubber Parts Kits:

0887297	RK 009 RT	1/4", 3/8", 1/2"
0887511	RK SS009 RT	1/2"
0886999	RK 009M2 RT	3/4"
0887521	RK SS009M2 RT	3/4"
0888526	RK 009M3 RT	3/4"
0888597	RK SS009M3 RT	1/4" - 3/4"
0887182	RK 009 RT	3/4" - 1"
0887530	RK SS009 RT	1"
0887787	RK 009M2 RT	1"

Kit consists of: Diaphragm, Two discs, Two disc assemblies, Stem O-rings, Cover O-ring, Two seat O-rings and RV seat O-ring.

Cover Kits:

0887296	RK 009 C	1/4", 3/8", 1/2"
0887500	RK SS009 C	1/2"
0887004	RK 009M2 C	3/4"
0887501	RK SS009M2/M3 C	1/4" - 3/4"
0888525	RK 009M3 C	3/4"
0887013	RK 009 C	3/4" - 1"
0887502	RK SS009 C	1"
0887788	RK 009M2 C	1"

Kit consists of: Cover and Cover O-ring.

1 1/4" - 2"

ORDERING CODE	KIT NO.	SIZE
---------------	---------	------

Relief Valve Total Kit:

0887307	RK 009M2 VT	1 1/4" - 1 1/2"
0887277	RK 009M1 VT	1 1/4" - 2"
0887016	RK 009 VT	1 1/4" - 2"
0887545	RK 009M2 VT	2"

Kit consists of: RV assembly, Seat, Seat O-ring, Cover O-ring, Sensing passage O-ring and Upper stem O-ring.

Relief Valve Rubber Parts Kit:

0887306	RK 009M2 RV	1 1/4" - 1 1/2"
0887276	RK 009M1 RV	1 1/4" - 2"
0887184	RK 009 RV	1 1/4" - 2"
0887544	RK 009M2 RV	2"

Kit consists of: Diaphragm, Seat O-ring, Cover O-ring and Sensing passage O-ring.

Complete Rubber Parts Kit:

0887309	RK 009M2 RT	1 1/4" - 1 1/2"
0887280	RK 009M1 RT	1 1/4" - 2"
0887185	RK 009 RT	1 1/4" - 2"
0887547	RK 009M2 RT	2"

Kit consists of: Two check assembly O-rings, Two disc assemblies, One cover O-ring, One RV diaphragm, One RV seat O-ring, One sensing passage O-ring, One diaphragm plate O-ring, One RV lower stem O-ring, One RV upper stem O-ring, One RV disc assembly and One bleed screw O-ring.

Cover Kit:

0887308	RK 009M2 C	1 1/4" - 1 1/2"
0887278	RK 009M1 C	1 1/4" - 2"
0887014	RK 009 C	1 1/4" - 2"
0887546	RK 009M2 C	2"

Kit consists of: Cover, Cover O-ring, Sensing passage O-ring, Bleed screw O-ring, Vent hood and Bleed screw.

Servicing First & Second Check Valves

1/4" - 2"

1. Remove the retainer from the body bore. The check valve modules can now be removed from the valve by hand or with a screwdriver. **Note:** The seats and springs of the first and second check modules are not interchangeable. The heavier spring and smaller diameter seat belong with the first check module.

2. The check seats are attached to the cage with a bayonet type locking arrangement. Holding the cage in one hand, push the seat inward and rotate clockwise against the cage. The seat, spring cage, spring and disc assembly are now individual components.

Note: 3/4" M2 modules snap apart.

3. The disc assembly may now be cleaned and re-assembled or, depending on its condition, may be discarded and replaced with a new assembly from the repair kit. O-rings should be cleaned or replaced as necessary and lightly greased with the FDA approved grease. Refer to parts price list, PL-RP-BPD for more information.

4. Re-assemble the check valve modules. Check modules are installed in the valve body with the seat facing the valve inlet. The modules must be secured in place before the retainer can be replaced. On the 3/4" size retainer may have to be tilted slightly into place. Replace relief valve assembly.

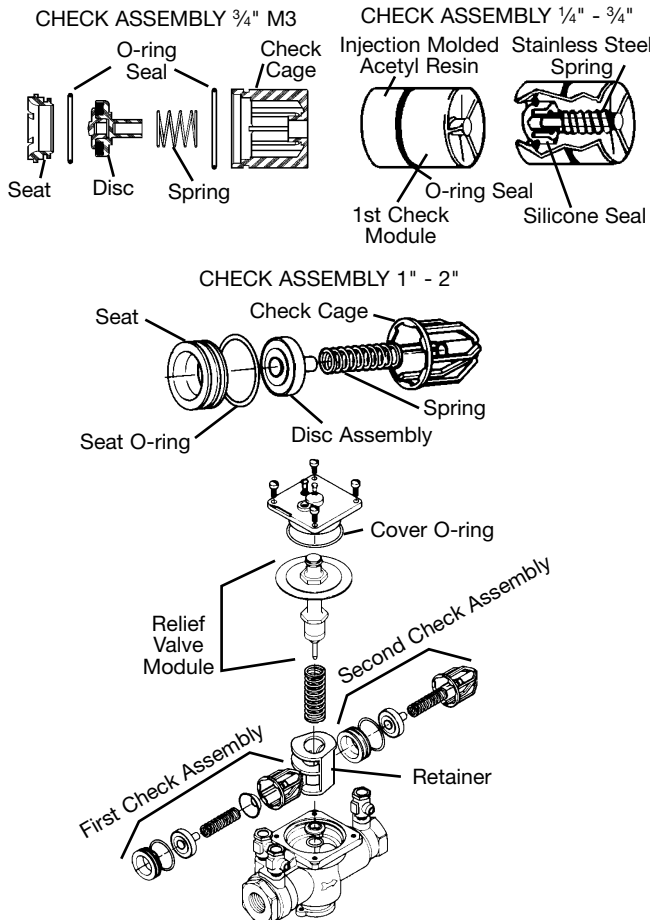

Watts reserves the right to change or modify product design, construction, specifications, or materials without prior notice and without incurring any obligation to make such changes and modifications on Watts products previously or subsequently sold.

Replacement Parts — 1/4" - 2"

When ordering, specify Ordering Code, Kit number and Valve Size.

1/4" - 1"

ORDERING CODE	KIT NO.	SIZE
First Check Kits:		
0887291	RK 009 CK1	1/4", 3/8", 1/2"
0887505	RK SS009 CK1	1/2"
0887000	RK 009M2 CK1	3/4"
0887515	RK SS009M2/M3 CK1	1/4" - 3/4"
0888520	RK 009M3 CK1	3/4"
0887005	RK 009 CK1	3/4" - 1"
0887009	RK 009 CK1SS	3/4" - 1"
0887525	RK SS009 CK1	1"
0887789	RK 009M2 CK1	1"

Kit consists of: Check assembly and Cover O-ring.

Second Check Kits:

0887292	RK 009 CK2	1/4", 3/8", 1/2"
0887506	RK SS009 CK2	1/2"
0887001	RK 009M2 CK2	3/4"
0887516	RK SS009M2/M3 CK2	1/4" - 3/4"
0888521	RK 009M3 CK2	3/4"
0887007	RK 009 CK2	3/4" - 1"
0887011	RK 009 CK2SS	3/4" - 1"
0887526	RK SS009 CK2	1"
0887790	RK 009M2 CK2	1"

Kit consists of: Check assembly and Cover O-ring.

Check Rubber Parts:

0887293	RK 009 RC3	1/4", 3/8", 1/2"
0887003	RK 009M2 RC3	3/4"
0888522	RK 009M3 RC3	3/4"
0887507	RK SS009 RC1	1/2"
0887517	RK SS009M2 RC1	3/4"
0888595	RK SS009M3 RC1	1/4" - 3/4"
0887017	RK 009 RC1	3/4" - 1"
0887527	RK SS009 RC1	1"
0887791	RK 009M2 RC1	1"
0887508	RK SS009 RC2	1/2"
0887518	RK SS009M2 RC2	3/4"
0888596	RK SS009M3 RC2	1/4" - 3/4"
0887180	RK 009 RC2	3/4" - 1"
0887528	RK SS009 RC2	1"
0887792	RK 009M2 RC2	1"

Kit consists of: Disc, Cover O-ring and Seat O-ring.

Retainers:

1047053	99AB47	1/4", 3/8", 1/2"
1047394	99BA47	3/4" M2-M3
1047001	99FA47	1 1/4" - 2"
1047001	99FA47	1 1/4" - 2" M1, 2" M2
1047401	99EA47	1 1/4" - 1 1/2" M2

1 1/4" - 2"

ORDERING CODE	KIT NO.	SIZE
First Check Kit:		
0887300	RK 009M2 CK1	1 1/4" - 1 1/2"
0887270	RK 009M1 CK1	1 1/4" - 2"
0887006	RK 009 CK1	1 1/4" - 2"
0887010	RK 009 CK1SS	1 1/4" - 2"
0887272	RK 009M1 CK1SS	1 1/4" - 2"
0887540	RK 009M2 CK1	2"

Kit consists of: First check assembly, Cover O-ring and Sensing passage O-ring.

Second Check Kit:

0887301	RK 009M2 CK2	1 1/4" - 1 1/2"
0887271	RK 009M1 CK2	1 1/4" - 2"
0887008	RK 009 CK2	1 1/4" - 2"
0887012	RK 009 CK2SS	1 1/4" - 2"
0887273	RK 009 M1 CK2SS	1 1/4" - 2"
0887541	RK 009M2 CK2	2"

Kit consists of: Second check assembly, Cover O-ring and Sensing passage O-ring.

First Check Rubber Parts Kit:

0887304	RK 009M2 RC1	1 1/4" - 1 1/2"
0887274	RK 009M1 RC1	1 1/4" - 2"
0887018	RK 009 RC1	1 1/4" - 2"
0887542	RK 009M2 RC1	2"

Kit consists of: First check assembly O-ring, Disc holder assembly, Cover O-ring and Sensing passage O-ring.

Second Check Rubber Parts Kit:

0887305	RK 009M2 RC2	1 1/4" - 1 1/2"
0887275	RK 009M1 RC2	1 1/4" - 2"
0887183	RK 009 RC2	1 1/4" - 2"
0887543	RK 009M2 RC2	2"

Kit consists of: Second check assembly O-ring, Disc holder assembly, Cover O-ring and Sensing passage O-ring.

Servicing the Relief Valve

2½" – 3"

1. Remove the four or six relief valve cover bolts while holding the cover down.
2. Lift the cover straight off. The stem and diaphragm assembly will normally remain with the cover as it is removed. The relief valve spring will be free inside the body at this point.
3. The relief valve seat is located at the bottom of the body bore, and can be removed, if necessary, for cleaning. The disc can be cleaned without disassembly of the relief valve module. If it is determined that the relief valve diaphragm and/or disc should be replaced, the relief valve module can be readily disassembled without the use of special tools.
Note: The disc rubber is molded into the disc holder and is supplied as a disc holder assembly.
4. To reassemble the relief valve, press the seat firmly into place in the body, center the spring on the seat, and insert the cover and relief valve module as a unit straight into the bore. Press down on the cover to assure proper alignment. Insert and tighten bolts.

Caution: If cover will not press flat against body, stem assembly is crooked and damage can result. Realign stem and cover before bolts are inserted.

NOTE: No special tools required to service Series 009 2½" - 3"

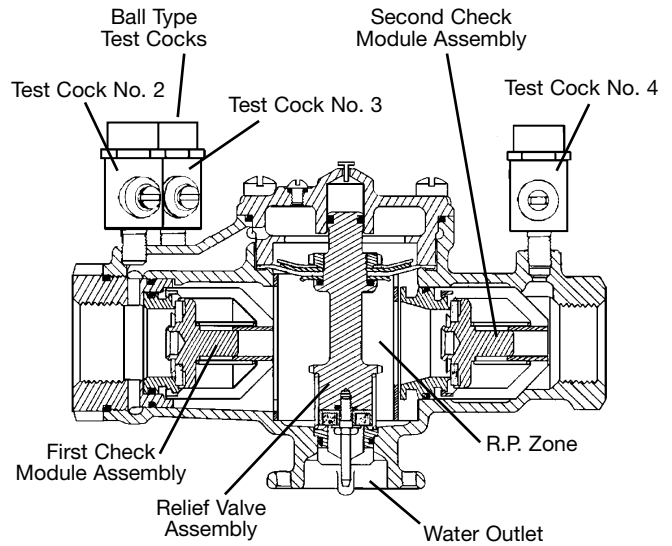

Replacement Parts — 2½" – 3"

When ordering, specify Ordering Code, Kit number and Valve Size.

ORDERING CODE	KIT NO.	SIZE
---------------	---------	------

Relief Valve Total Kit:

0887021	RK 009 VT	2½" - 3"
---------	-----------	----------

Kit consists of: Seat, Stem assembly, Spring, Two piston o-rings, Flow tube O-rings and Cover O-ring.

Relief Valve Rubber Parts Kit:

0887206	RK 009 RV	2½" - 3"
---------	-----------	----------

Kit consists of: Diaphragm, Disc, Molded disc assembly, Piston O-rings, Stem O-ring and Cover O-ring.

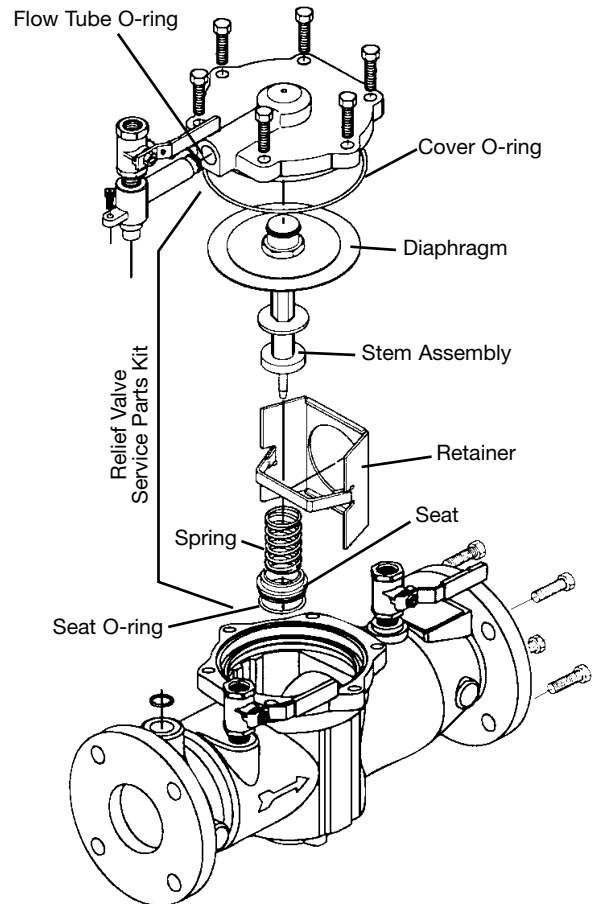

Servicing First & Second Check Valves

2½" – 3"

1. Remove the relief valve assembly as outlined on page 5.
2. Remove the retainer from the body bore. The check valve modules can now be removed from the valve by hand or with a screwdriver. **Note:** The seats and springs of the first and second check modules are not interchangeable. The heavier spring and smaller diameter seat belong with the first check module.
3. The check seats are attached to the cage with a bayonet type locking arrangement. Holding the cage in one hand, push the seat inward and rotate counterclockwise against the cage. The seat, spring cage, spring and disc assembly are now individual components.
4. The disc assembly may now be cleaned and reassembled or, depending on its condition, may be discarded and replaced with a new assembly from the repair kit. O-rings should be cleaned or replaced as necessary and lightly greased with the FDA approved silicon grease. For more information refer to repair parts price list PL-RP-BPD.
5. Reassemble the check valve modules. Check modules are installed in the valve body with the seat facing the valve inlet. The modules must be securely in place before the retainer can be replaced. Replace relief valve assembly.

NOTE: No special tools required to service Series 009 2½" - 3"

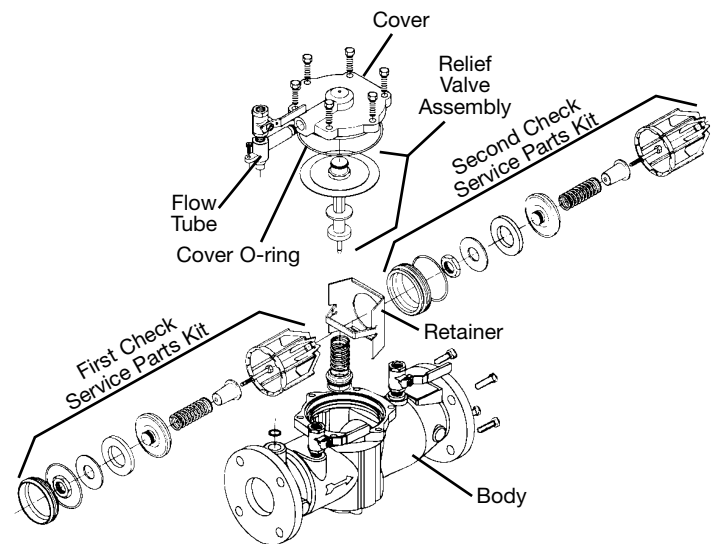
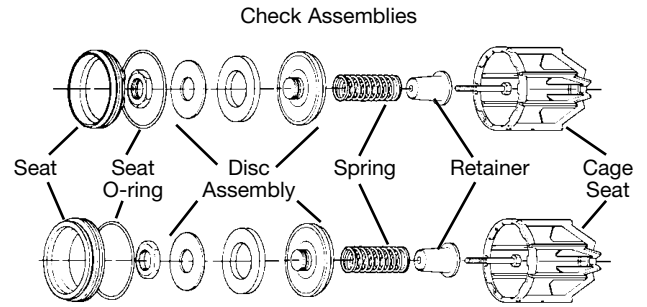

Replacement Parts — 2½" – 3"

When ordering, specify Ordering Code, Kit number and Valve Size.

ORDERING CODE	KIT NO.	SIZE
First Check Kit:		
0887019	RK 009 CK1	2½" - 3"

Second Check Kit:		
0887020	RK 009 CK2	2½" - 3"

Kit consists of: Check assembly, Cover O-ring and Flow tube O-ring.

First Check Rubber Parts Kit		
0887281	RK 009 RC1	2½" - 3"

Second Check Rubber Parts Kit		
0887205	RK 009 RC2	2½" - 3"

Kit consists of: Disc, Seat O-ring and Flow tube O-ring.

Total Rubber Parts:		
0887207	RK 009 RT	2½" - 3"

Kit consists of: Diaphragm, Two discs, Two molded disc assemblies, Two seat O-rings, RV O-ring, Two piston O-rings, RV stem O-ring, Flow tube O-rings and Cover O-ring.

Cover Kit:		
0887282	RK 009 C	2½" - 3"

Kit consists of: Cover, Cover O-ring and Flow tube O-ring.

Seat Kit:		
0887208	RK 009 S	2½" - 3"

Kit consists of: Check seat, Seat O-ring and Cover O-ring.

Test Procedures

Reduced Pressure Zone Assemblies

Reduced Pressure Zone Assemblies must be inspected and tested periodically, in accordance with local codes, to ensure proper operation of check valves within the unit.

A differential pressure gauge is recommended for Test No. 1 rather than a manometer for the following reasons: It utilizes minimum time to perform the test. It eliminates the necessity of closing the inlet ball valve which could release pipe scale and foreign matter into the backflow preventer. Only a slight amount of water is 'spilled' in test. A mercury manometer could cause a pollution hazard.

Test Set Up

Reduced Pressure Zone Assembly

Close Valves A, B and C on Test Kit.
 Connect high side hose to test cock #2
 Connect low side hose to test cock #3. Close shutoff #2.
 Open test cocks #2 and #3.
 Open vent valve C.
 Open 'high' valve A and bleed to atmosphere until all the air is expelled.
 Close valve A. Open 'low' valve B and bleed to atmosphere until all air is expelled. Close 'low' valve B. Close 'vent' valve C.
 Connect vent hose to test cock #4.

Test Procedure

Reduced Pressure Zone Assembly

Field Test Equipment Required
 Reduced Pressure Zone Backflow Preventer Test Kit

Test No. 1

Purpose: To test Check Valve No. 2 for tightness against reverse flow.
Requirements: Valve must be tight against reverse flow under all pressure differentials. Slowly open the 'high' valve A and the 'vent' valve C, and keep the 'low' valve B closed. Open test cock #4. Indicated pressure differential will decrease slightly. If pressure differential continues to decrease (until the vent opens) check valve #2 is reported as 'leaking'.

Test No. 2

Purpose: To test shutoff #2 for tightness.
Requirements: After passing Test No. 1, continue to Test No. 2 by closing test cock #2. The indicated pressure differential will decrease slightly. If pressure differential continues to decrease (approaching "zero"), shutoff #2 is reported to be "leaking".

Test No. 3

Purpose: To test Check Valve No. 1 for tightness.
Requirements: Valve must be tight against reverse flow under all pressure differentials. Close 'high' valve A and open test cock

#2. Close test cock #4. Disconnect vent hose at test cock #4. Open valves B and C, bleeding to atmosphere. Then closing valve B restores the system to a normal static condition. Observe the pressure differential gauge. If there is a decrease in the indicated value, Check Valve No. 1 is reported as "leaking".

Test No. 4

Purpose: To test operation of pressure differential relief valve.
Requirements: The pressure differential relief valve must operate to maintain the "zone" between the two check valves at least 2psi less than the supply pressure. Close 'vent' valve C. Open 'high' valve A. Open the 'low' valve B very slowly until the differential gauge needle starts to drop. Hold the valve at this position and observe the gauge reading at the moment the first discharge is noted from the relief valve. Record this as the opening differential pressure of the relief valve.

Note: It is important that the differential gauge needle drops slowly. Close test cocks #2 and #3. Use 'vent' hose to relieve pressure from test kit by opening valves A, B and C. Remove all test equipment and open shutoff #2.

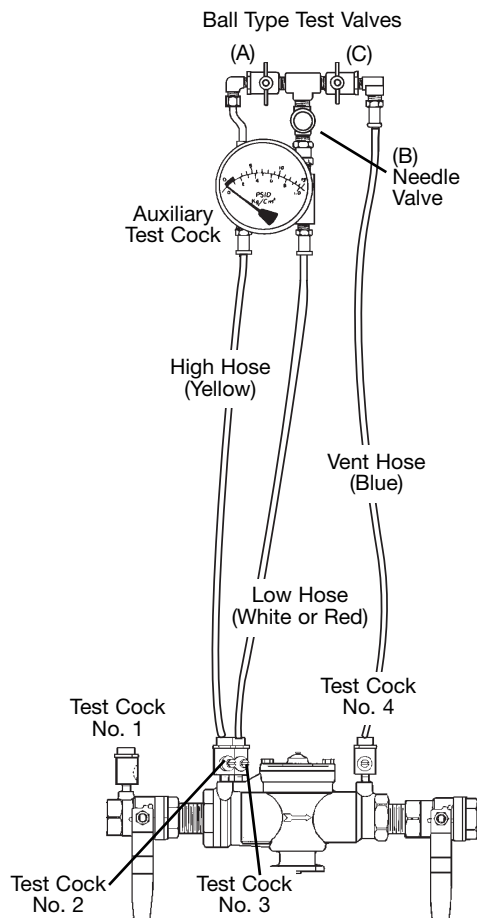

Caution: To prevent freezing, hold Test Kit vertically to drain differential gauge and hoses prior to placing in case.



Watts USA Website: www.wattsreg.com • Watts Canada Website: www.wattscda.com